

SECTION 3

PARKS & RECREATIONAL RESERVES

FENCING

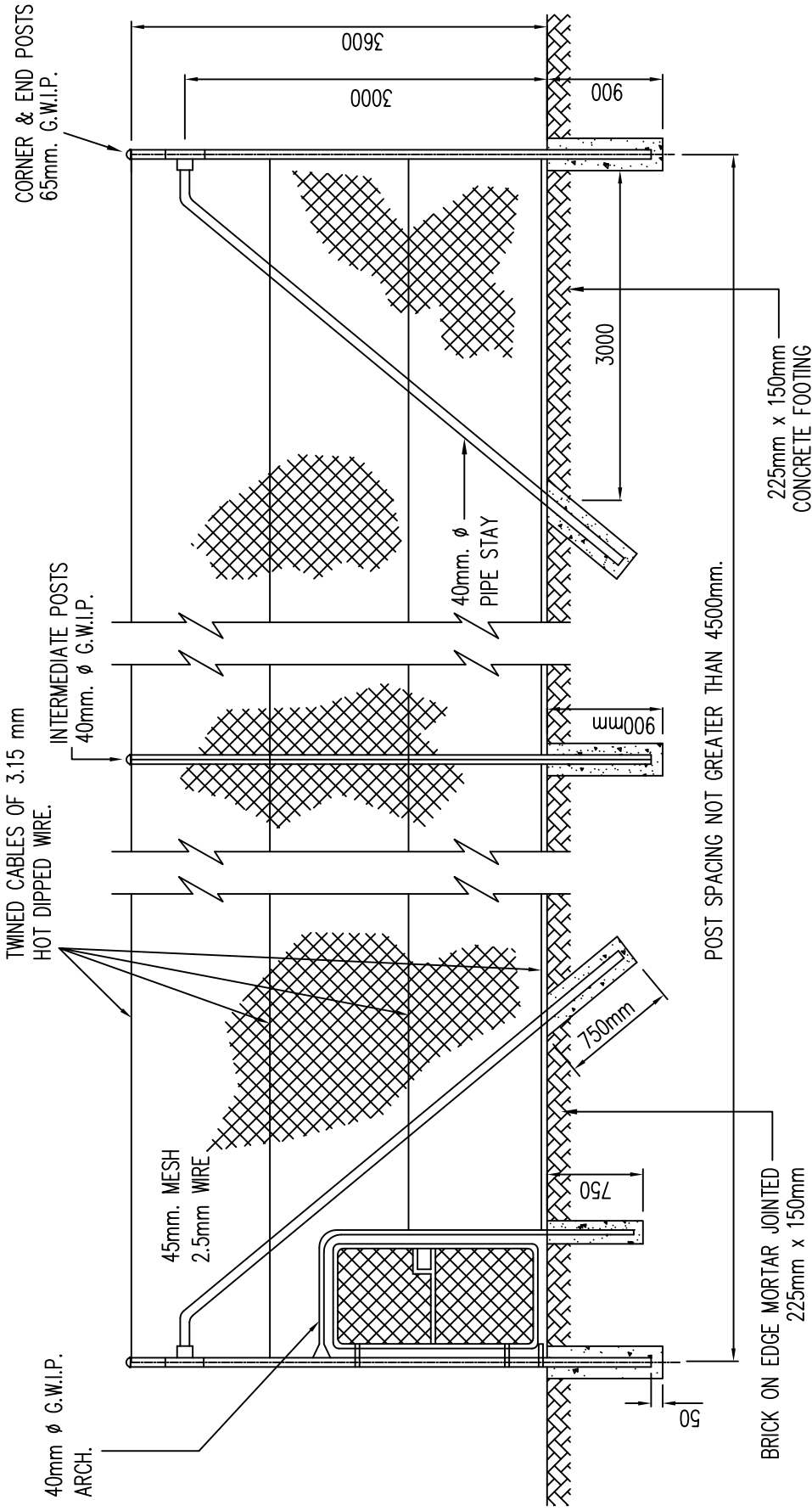

NOTES

1. ALL POST FOOTINGS TO BE 225 DIA
2. CONCRETE STRENGTH F'C = 20MPa.
3. G.W.I.P. GATES TO BE LOCATED AS SHOWN. GATE OPENING TO BE 2000mm. x 1050mm.
4. ALL DIMENSIONS ARE IN MILLIMETRES
5. ALL GATES TO OPEN OUTWARDS
6. (a) GALVANISED TENNIS MESH TO BE 45mm x 2.5mm
(b) PVC TENNIS MESH SHOULD BE 45mm x 2.5mm AND POSTS POWDERCOATED TO MATCH

CITY OF CASEY

**FENCING DETAILS
(TENNIS COURTS)**

AMENDMENTS: GENERAL UPGRADE

MANAGER OF ENGINEERING &
ENVIRONMENTAL SERVICES
LAST UPDATE 09.11.2012

S-701 V2

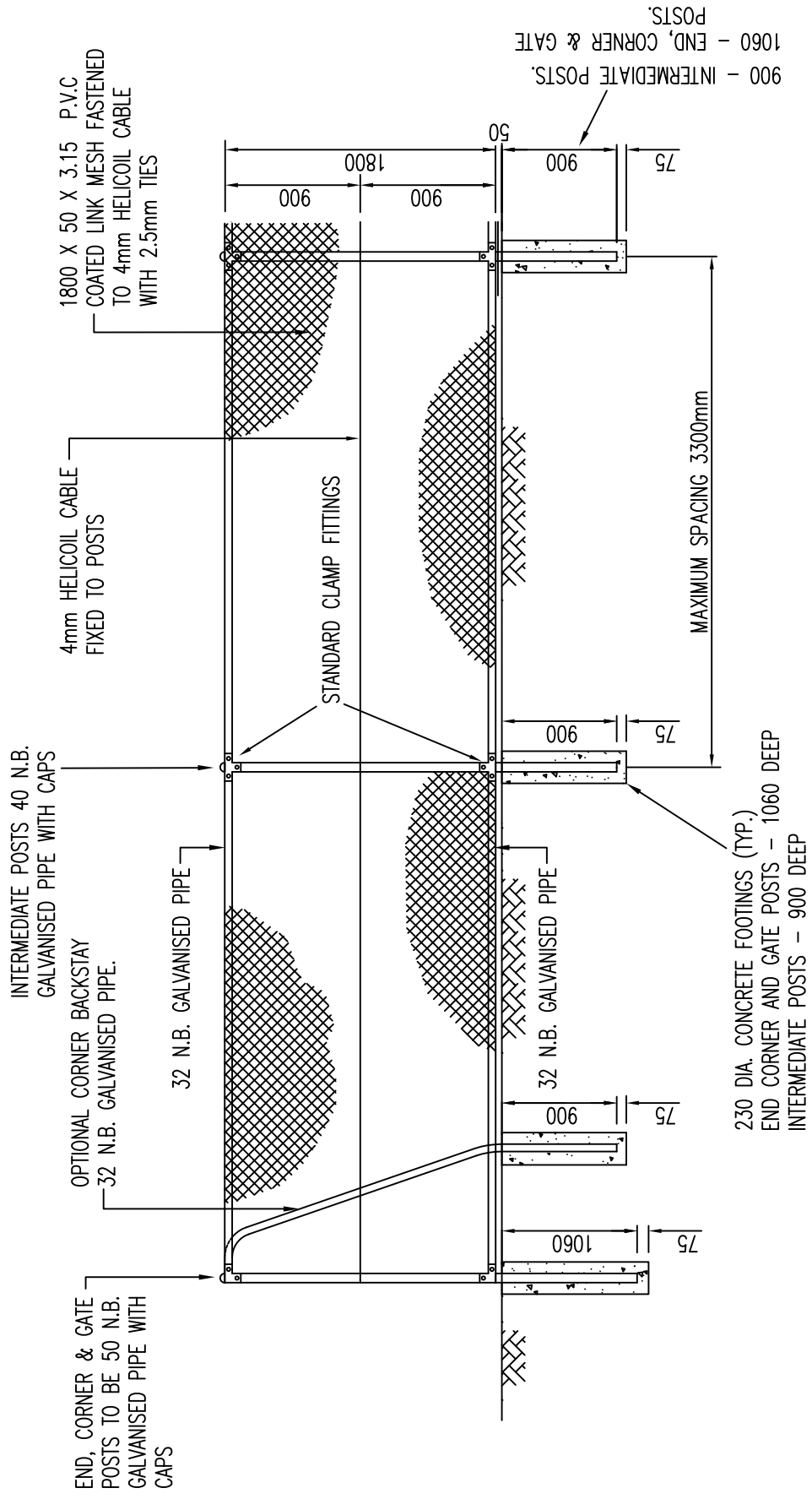

NOTES

1. CONCRETE STRENGTH F'C = 20MPa.
2. ALL DIMENSIONS ARE IN MILLIMETRES
3. FOR COLOURED (PVC COATED) FENCES ALL PIPES AND FITTINGS MUST BE POWDERCOATED,

CITY OF CASEY

**CHAIN WIRE FENCING
1800mm HIGH**

AMENDMENTS: HEIGHT AMENDED, BARBED WIRE DELETED

MANAGER OF ENGINEERING &
 ENVIRONMENTAL SERVICES
 LAST UPDATE 09.11.2012

S-702 V2

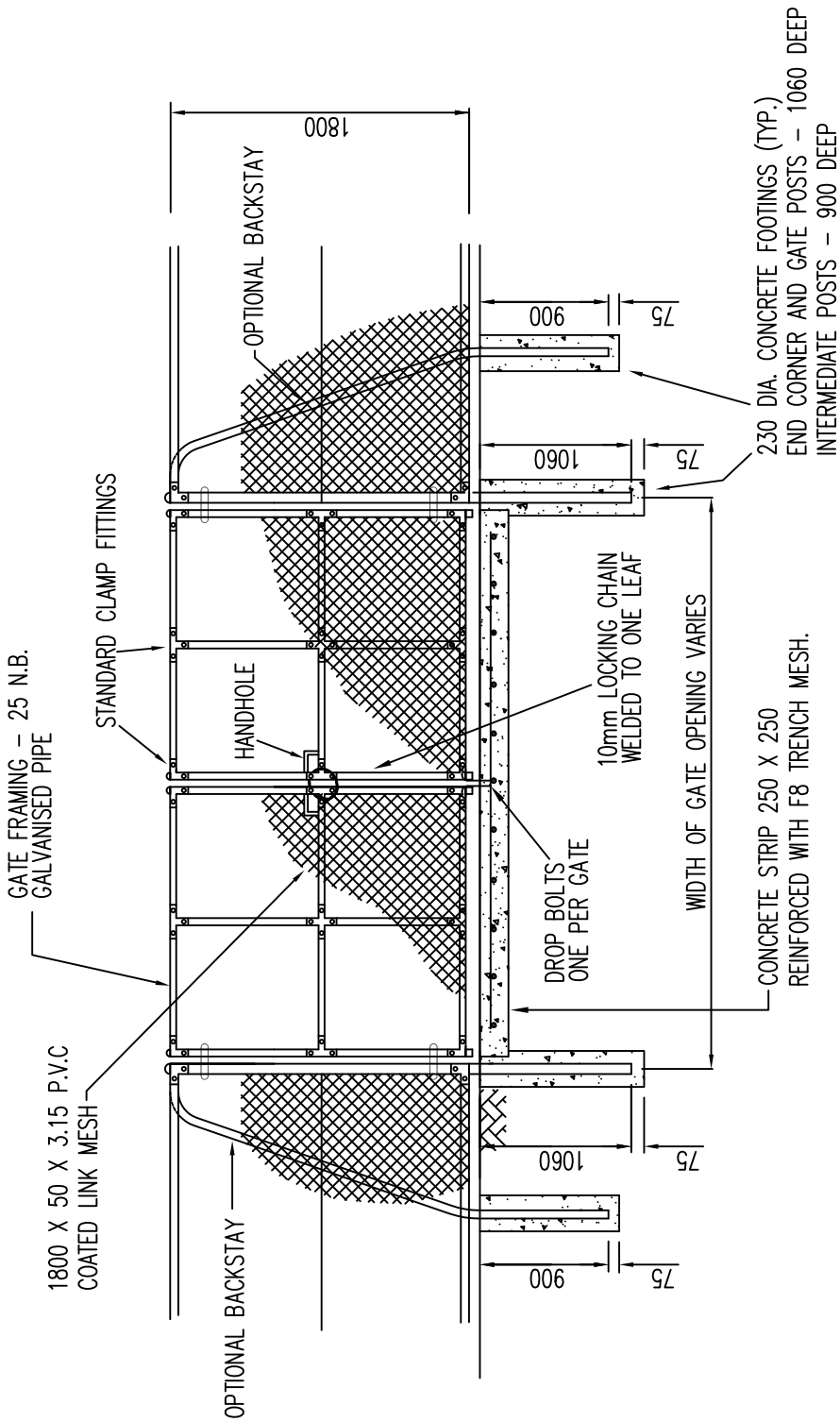

NOTES

1. CONCRETE STRENGTH F'C = 20MPa.
2. ALL DIMENSIONS ARE IN MILLIMETRES
3. FOR COLOURED (PVC COATED) FENCES ALL PIPES AND FITTINGS MUST BE POWDERCOATED,

CITY OF CASEY

CHAIN WIRE GATE DETAIL

AMENDMENTS: HEIGHT AMENDED, BARBED WIRE REMOVED



MANAGER OF ENGINEERING &
ENVIRONMENTAL SERVICES
LAST UPDATE 09.11.2012

S-702A V2

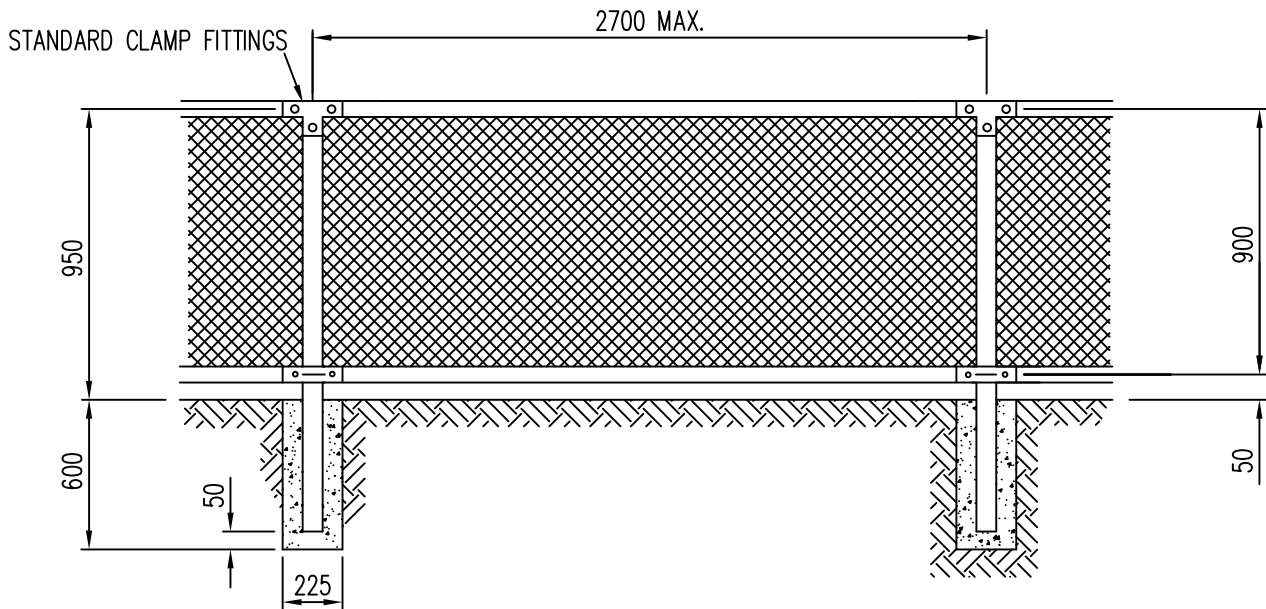

NOTES

1. THE NOMINAL PIPE SIZES TO BE USED ARE :
CORNER AND GATE POSTS - 80 mm.
INTERMEDIATE POSTS - 40 mm.
ALL RAILS - 32 mm.
2. ALL END POSTS AND GATE POSTS ARE TO BE CAPPED.
3. (a) GALVANISED FENCE MESH SHALL BE 50mm x 3.15mm
(b) PVC FENCE MESH SHALL BE 50mm x 3.15mm CORE
4. ALL MATERIALS ARE TO BE GALVANISED.
5. ALL FITTINGS TO BE MEDIUM GRADE
6. FOR COLOURED MESH FENCES ALL PIPES AND FITTINGS MUST BE POWDERCOATED
7. ALL DIMENSIONS ARE IN MILLIMETRES
8. CONCRETE STRENGTH F'C = 25MPa

CITY OF CASEY

CHAIN WIRE FENCING
900mm HIGH

MANAGER OF ENGINEERING &
ENVIRONMENTAL SERVICES
LAST UPDATE 09.11.2012

AMENDMENTS: FENCE MESH GAUGE INCREASED TO 3.15mm CORE

S-703A

V3

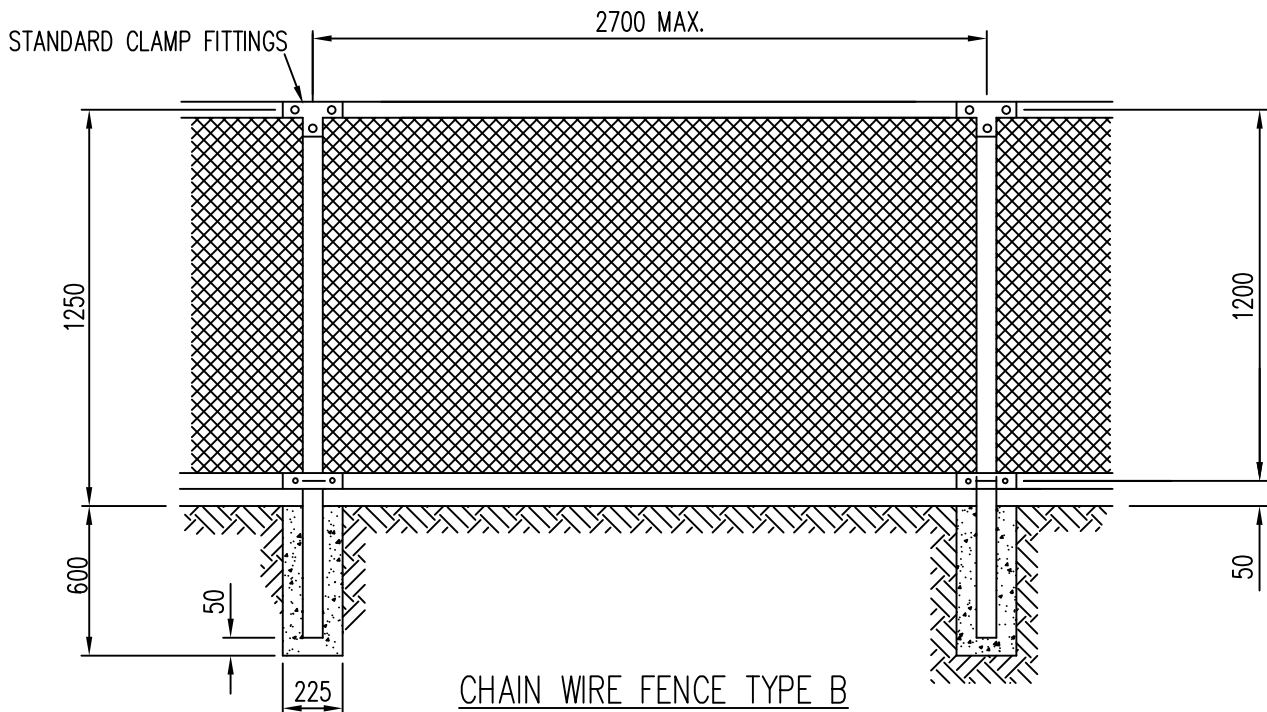

NOTES

1. THE NOMINAL PIPE SIZES TO BE USED ARE :
 - CORNER AND GATE POSTS - 80 mm.
 - INTERMEDIATE POSTS - 40 mm.
 - ALL RAILS - 32 mm.
2. ALL END POSTS AND GATE POSTS ARE TO BE CAPPED.
3. (a) GALVANISED FENCE MESH SHALL BE 50mm x 3.15mm
(b) PVC FENCE MESH SHALL BE 50mm x 3.15mm CORE
4. ALL MATERIALS ARE TO BE GALVANISED.
5. ALL FITTINGS TO BE MEDIUM GRADE
6. FOR COLOURED MESH FENCES ALL PIPES AND FITTINGS MUST BE POWDERCOATED
7. ALL DIMENSIONS ARE IN MILLIMETRES
8. CONCRETE STRENGTH F'C = 25MPa

CITY OF CASEY

CHAIN WIRE FENCING TYPE B
1200mm HIGH

Shahab

MANAGER OF ENGINEERING &
ENVIRONMENTAL SERVICES
LAST UPDATE 09.11.2012

AMENDMENTS: FENCE MESH GAUGE INCREASED TO 3.15mm CORE

S-703B

V3

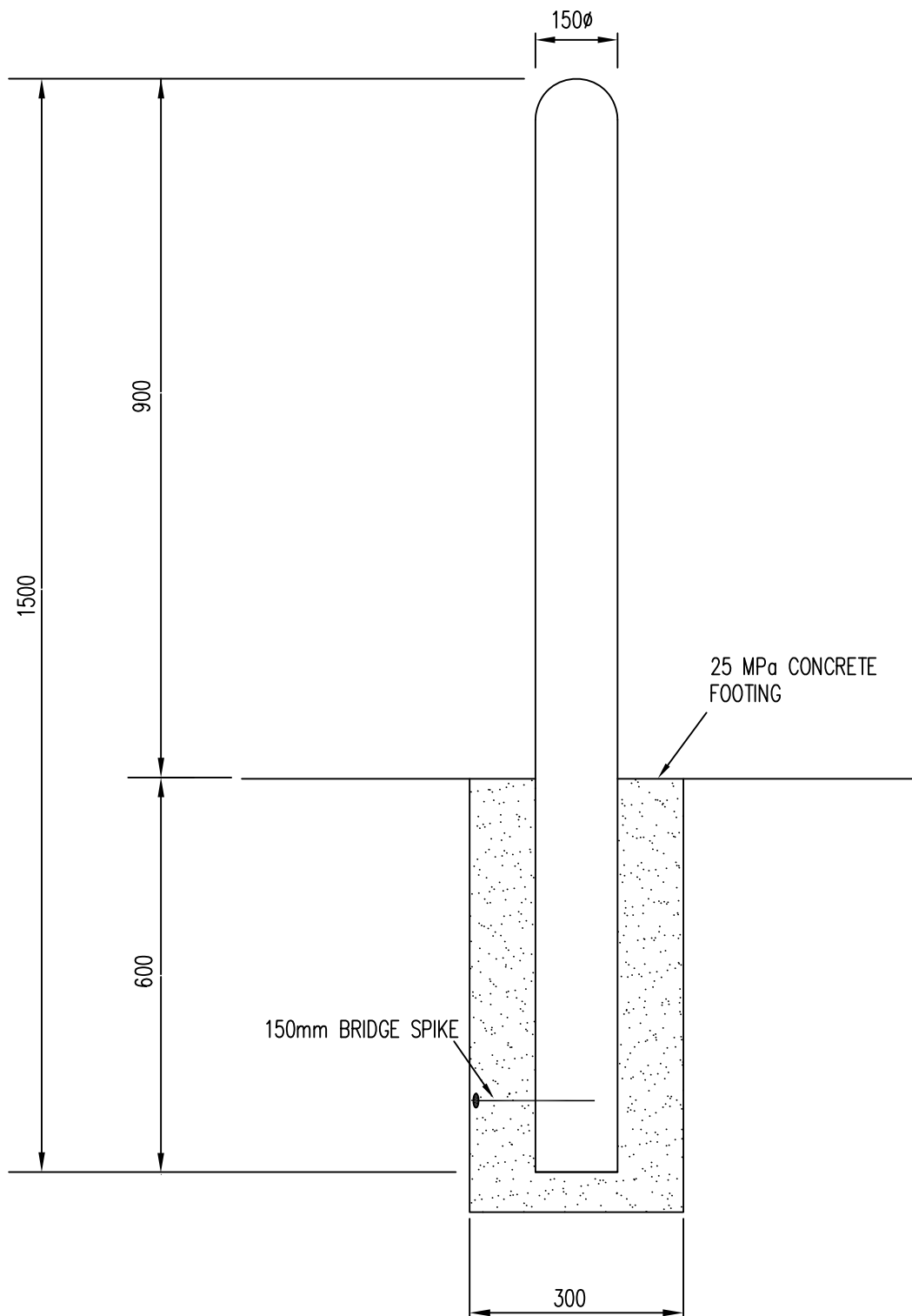

NOTE

WHERE BOLLARDS ARE TO BE INSTALLED IN CONCRETE PATHS OR OTHER LOCATIONS WHERE THEY MAY NEED TO BE REMOVED, A GALVANISED STEEL SLEEVE, 160 x 160mm IS TO BE USED - SEE DETAIL ON S-704D-V2

CITY OF CASEY

RECYCLED PLASTIC ROUND/ECO BOLLARD

AMENDMENTS: GENERAL UPGRADE

MANAGER OF ENGINEERING &
ENVIRONMENTAL SERVICES
LAST UPDATE 09.11.2012

S-704A

V2

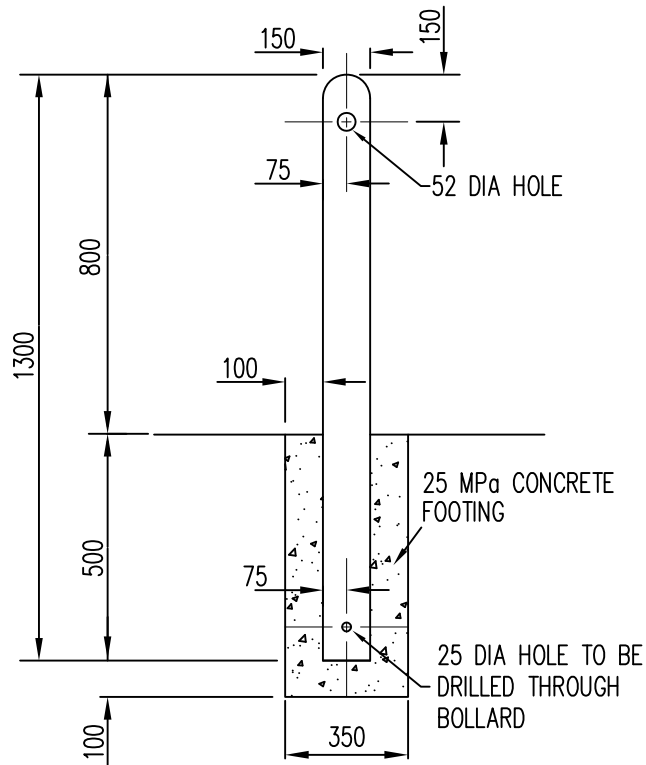

PEDESTRIAN ACCESS
GAP – PROVIDE A
GAP (NO RAIL)
EVERY FOURTH
SEGMENT

8550 MAX LENGTH OF POLE OVER 3 SECTIONS

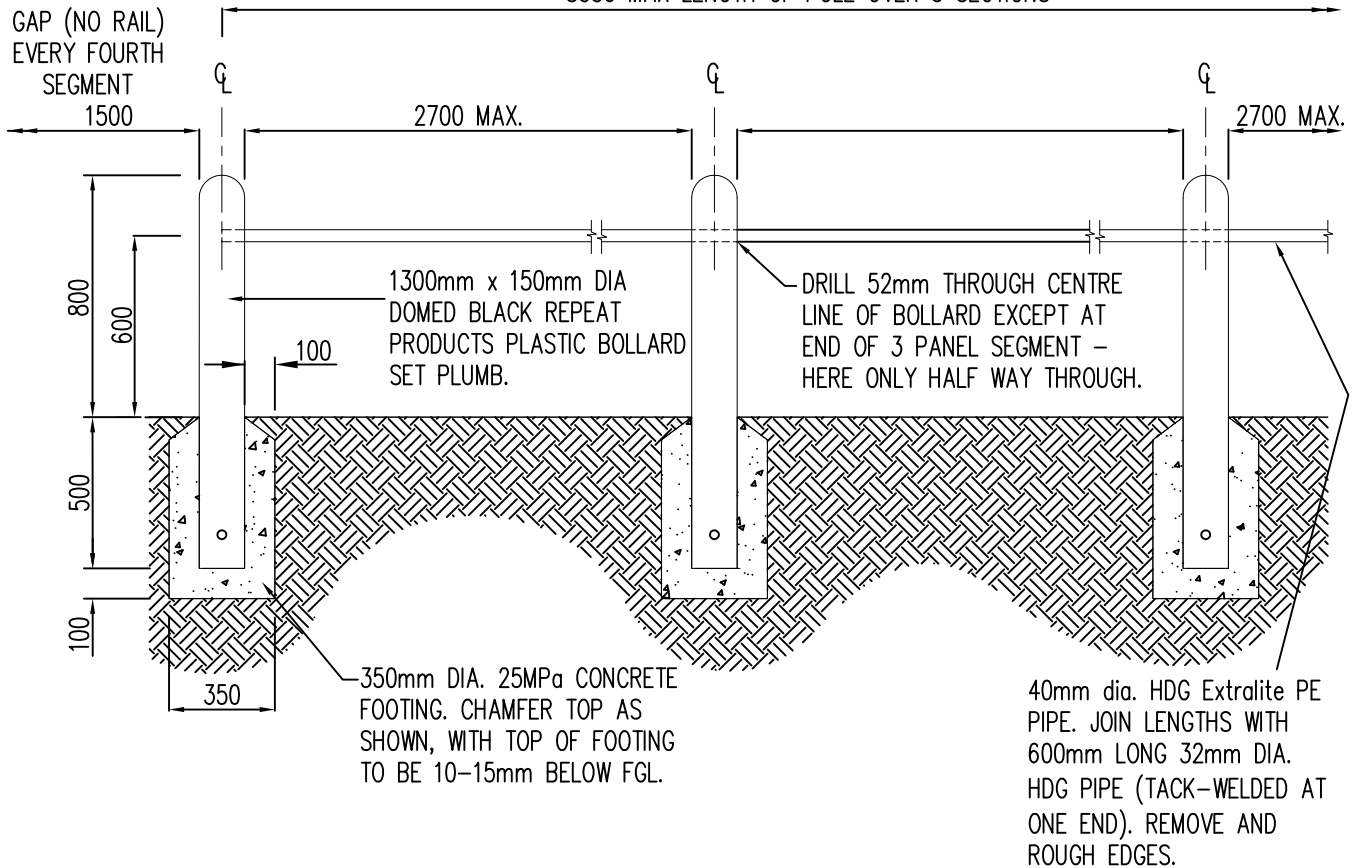

CITY OF CASEY

RECYCLED PET ECO BOLLARD WITH RAIL

Robert

MANAGER OF ENGINEERING &
ENVIRONMENTAL SERVICES

LAST UPDATE 09.11.2012

AMENDMENTS: GENERAL UPGRADE

S-704B

V2

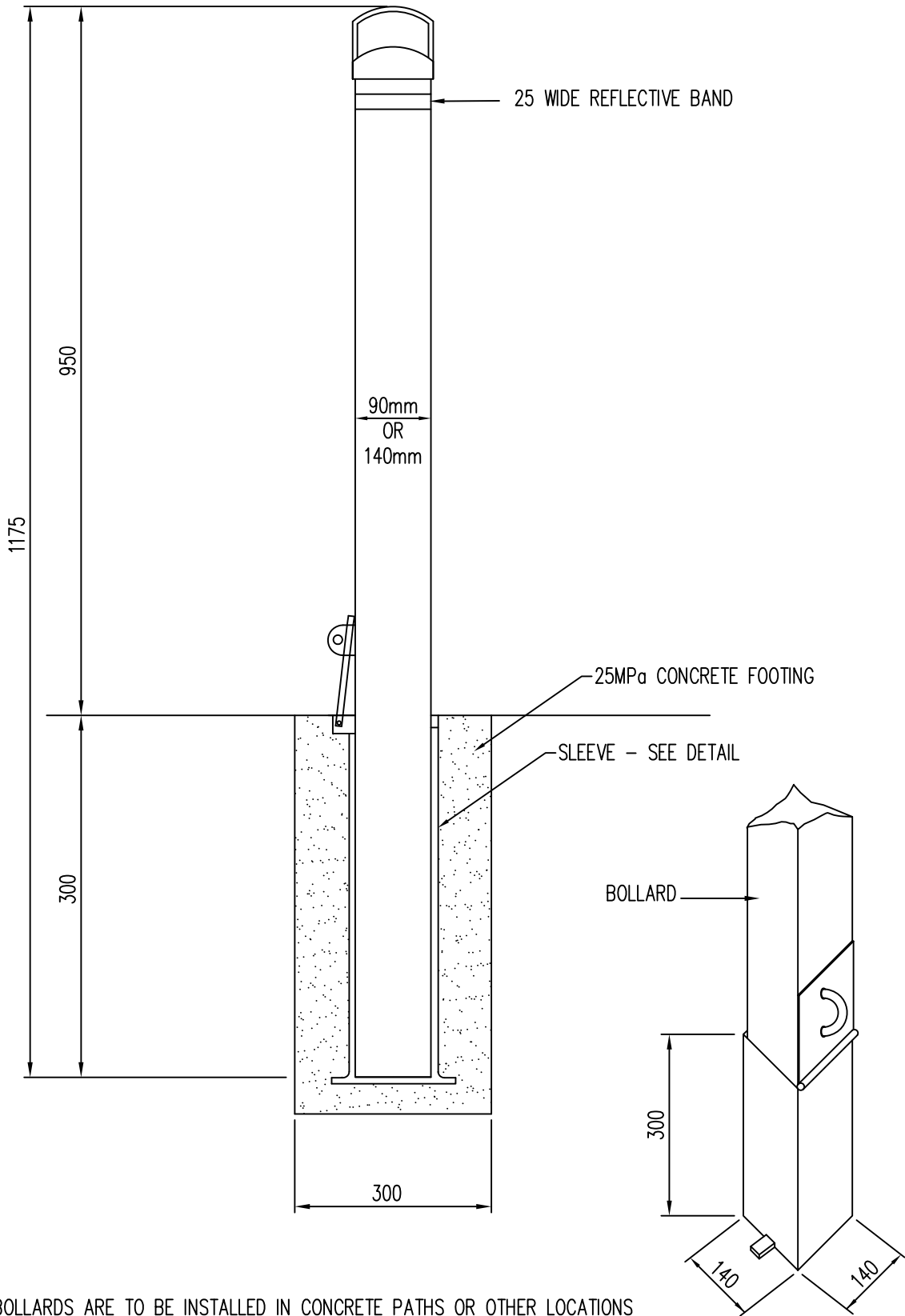

NOTE

WHERE BOLLARDS ARE TO BE INSTALLED IN CONCRETE PATHS OR OTHER LOCATIONS WHERE THEY MAY NEED TO BE REMOVED, A GALVANISED STEEL SLEEVE, 90 x 90mm OR 140 x 140mm IS TO BE USED - SEE DETAIL

SLEEVE DETAIL

CITY OF CASEY

REMOVABLE BOLLARD POST

Robert

MANAGER OF ENGINEERING &
ENVIRONMENTAL SERVICES
LAST UPDATE 09.11.2012

AMENDMENTS: GENERAL UPGRADE

S-704C

V2

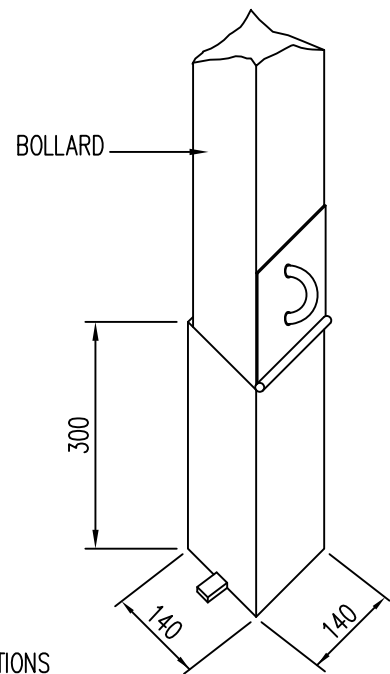
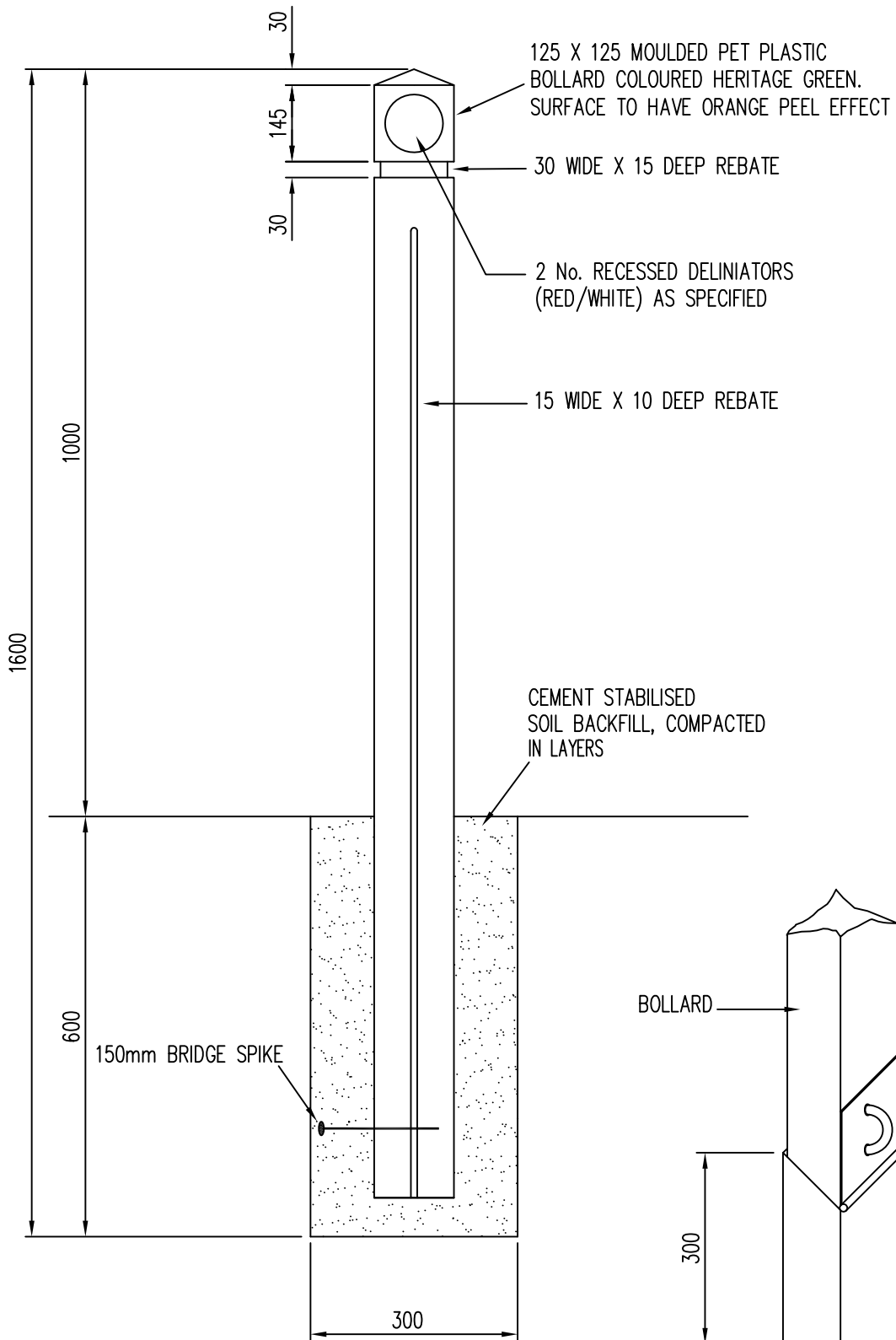

NOTE

WHERE BOLLARDS ARE TO BE INSTALLED IN CONCRETE PATHS OR OTHER LOCATIONS WHERE THEY MAY NEED TO BE REMOVED, A GALVANISED STEEL SLEEVE, 140 x 140mm IS TO BE USED – SEE DETAIL

SLEEVE DETAIL

CITY OF CASEY

RECYCLED PET PLASTIC BOLLARD FIXED

Robert

MANAGER OF ENGINEERING &
ENVIRONMENTAL SERVICES
LAST UPDATE 09.11.2012

AMENDMENTS: GENERAL UPGRADE

S-704D

V2

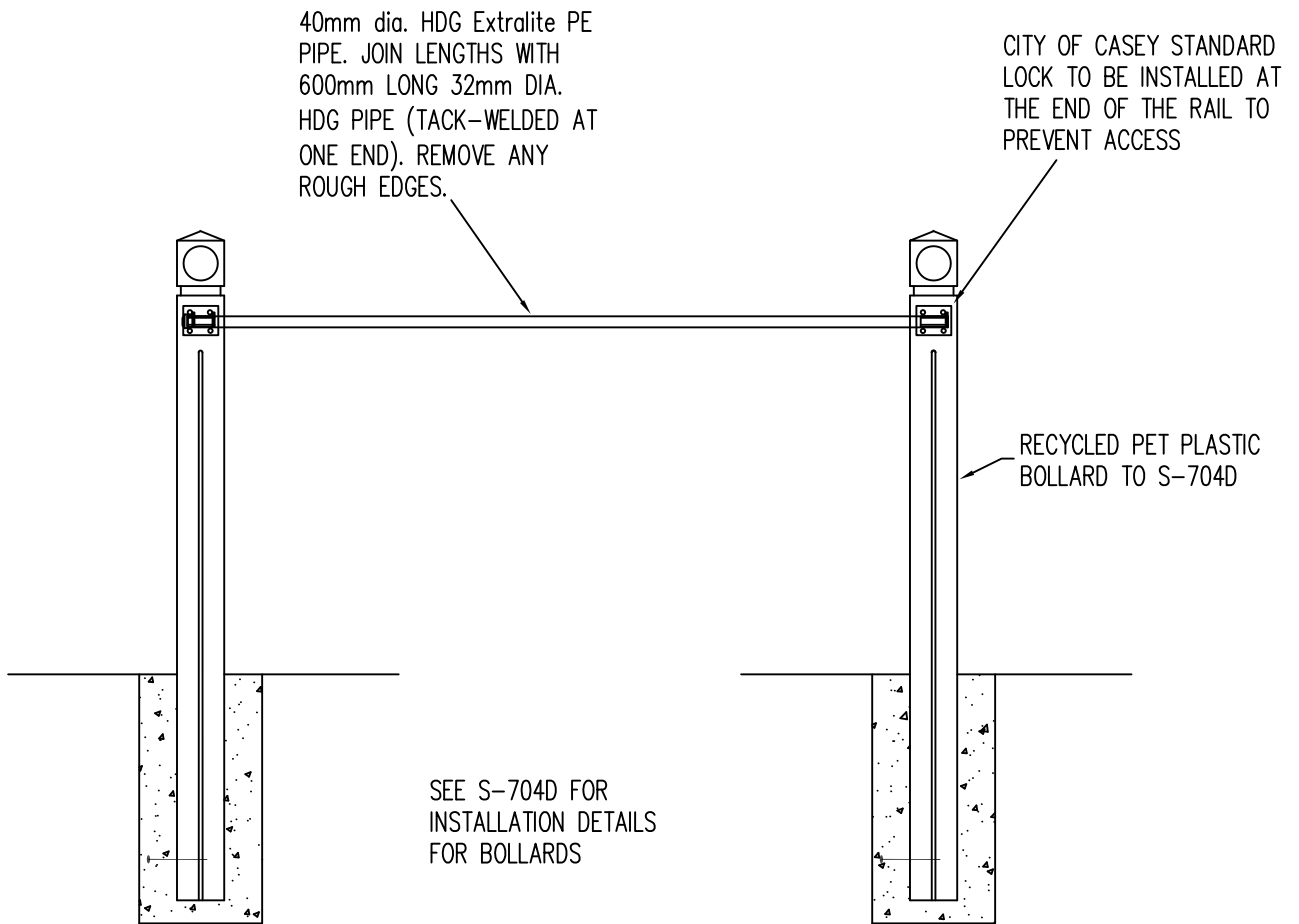

CITY OF CASEY

RECYCLED PET PLASTIC BOLLARD FIXED RAILING GATE

AMENDMENTS: GENERAL UPGRADE

MANAGER OF ENGINEERING & ENVIRONMENTAL SERVICES

LAST UPDATE 09.11.2012

S-704E

V2

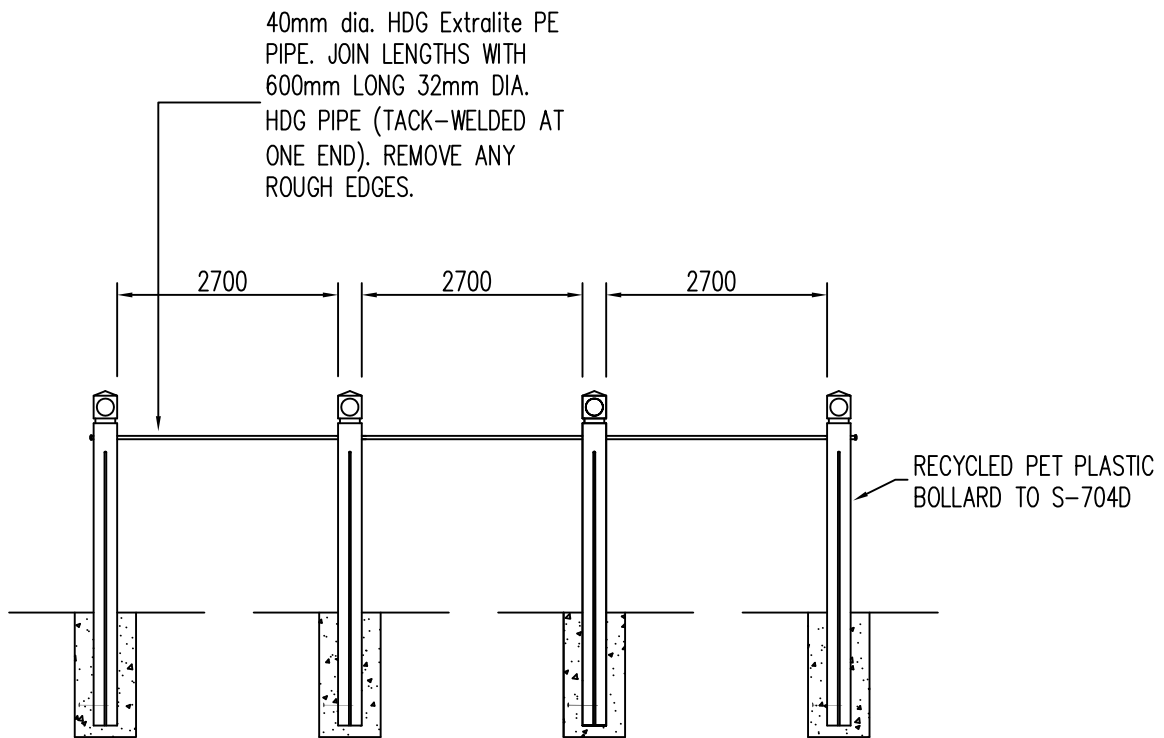

SEE S-704D FOR
INSTALLATION DETAILS
FOR BOLLARDS

ELEVATION

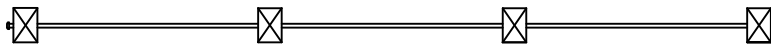

PLAN VIEW

NOTES

1. GALVANISED RAIL TO GO COMPLETELY THROUGH EACH BOLLARD – REFER TO ECO BOLLARD DETAIL. DRILL 52mm DIAMETER HOLE THROUGH BOLLARD.
2. EACH BOLLARD HAS A 32mm GALVANISED JOINER WHERE THE 40mm GALVANISED EXTRALITE POLE IS JOINED ON TO.

CITY OF CASEY

RECYCLED PET PLASTIC BOLLARD FIXED
RAILING FENCE

MANAGER OF ENGINEERING &
ENVIRONMENTAL SERVICES
LAST UPDATE 09.11.2012

AMENDMENTS: GENERAL UPGRADE

S-704F

V2

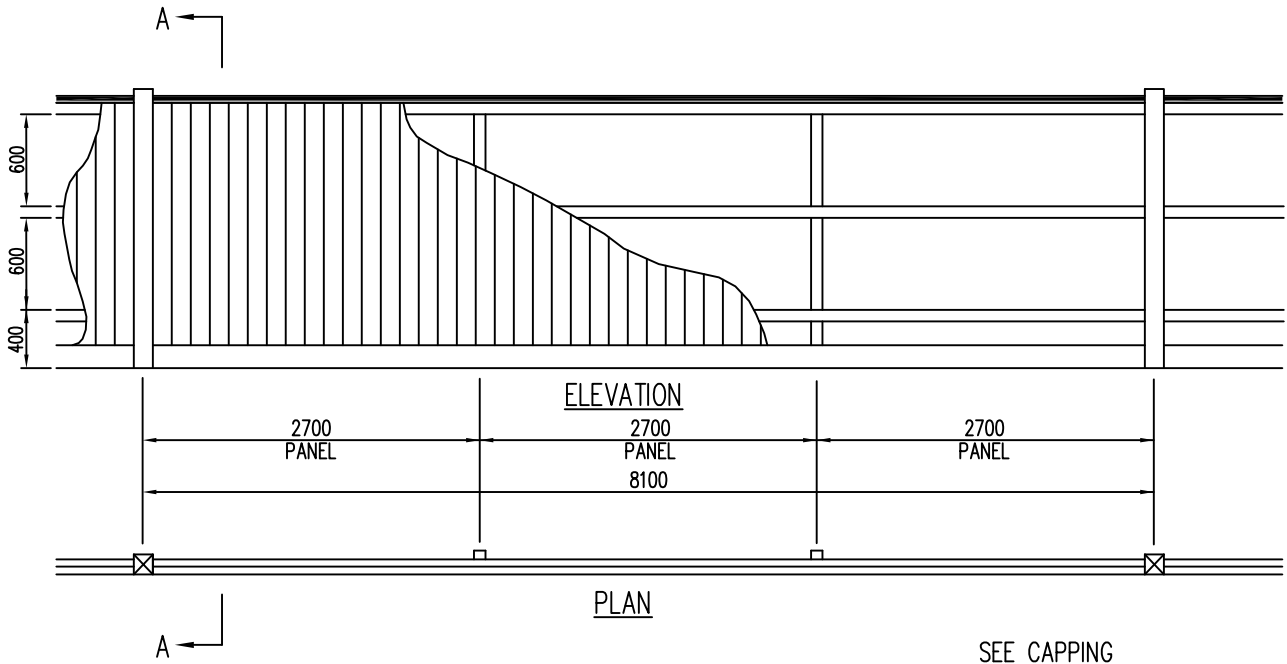

NOTES

POSTS

POSTS ARE TO BE REDGUM, IRON BARK OR CYPRESS PINE.
 EXPOSED POSTS TO BE PAINTED ON BOTH SIDES
 POSTS ARE TO BE 125 x 75, 2600 LONG AND SET PLUMB AT 2700 CENTRES. ONLY TWO RAIL JOINTS ALLOWED PER POST EXCEPT AT CHANGE OF GRADE.

RAILS/CAPPING

RAILS ARE TO BE HARDWOOD
 RAILS ARE TO SPAN TWO PANELS AND BE NOTCHED 50mm INTO POSTS
 CAPPING TO BE PAINTED.

FENCE MATERIALS

POST PROUDL (TREATED PINE)	125 x 125
POSTS (HARDWOOD)	125 x 75
TOP & BOTTOM RAIL (HARDWOOD)	75 x 50
CENTRE RAIL (HARDWOOD)	75 x 50
PLINTH (TREATED PINE)	150 x 25
PALINGS (TREATED PINE)	150 x 25
CAPPING (TREATED PINE) AS PER DETAIL	
GALVANISED NAILS	

ALL FENCE COMPONENTS VISIBLE ARE TO BE PAINTED GREEN INCLUDING SIDES OF EXPOSED POSTS, TOPS OF POSTS AND CAPPING.

BOARDS (PALINGS)/PLINTH

TREATED PINE (TO AS 1604 1980) AND PAINTED GREEN TO HAVE 25mm OVERLAP ON EACH SIDE

LATERAL STABILISATION

THE FENCE IS TO BE STABILISED BY PLACING ONE RETURN PANEL EVERY ALLOTMENT BOUNDARY UNLESS DIRECTED BY THE WORKS SUPERVISOR.

IMPORTANT

WHERE EXISTING TREE RESERVE FENCE IS OF A DIFFERENT (APPROVED) STANDARD IT WILL BE NECESSARY TO CHECK WITH THE SUPERINTENDENT WHICH FENCE TYPE SHALL BE USED.

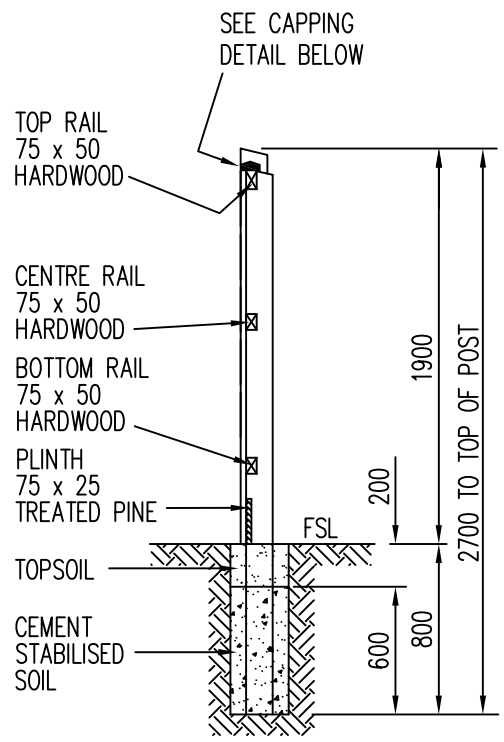

SECTION A-A

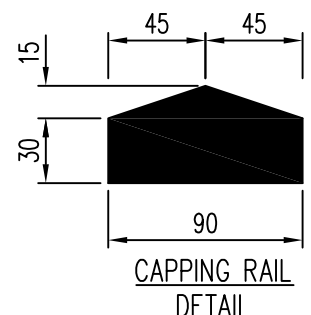

CITY OF CASEY

STANDARD TREE RESERVE FENCE

AMENDMENTS: GENERAL UPGRADE

Robert

MANAGER OF ENGINEERING & ENVIRONMENTAL SERVICES

LAST UPDATE 09.11.2012

S-706

V2

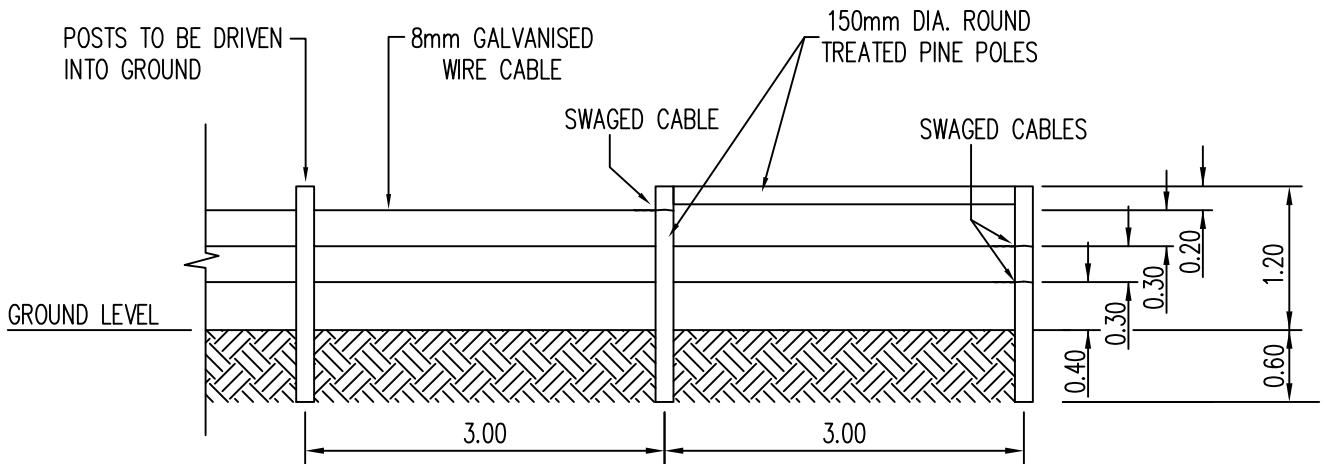

NOTES

1. WHERE POOR GROUND CONDITIONS EXIST, IT MAY BE NECESSARY TO PLACE CONCRETE AROUND BASE OF POSTS.

CITY OF CASEY

TREATED PINE POST AND CABLE FENCE

MANAGER OF ENGINEERING &
ENVIRONMENTAL SERVICES
LAST UPDATE 09.11.2012

AMENDMENTS:

S-707

MISCELLANEOUS DETAILS

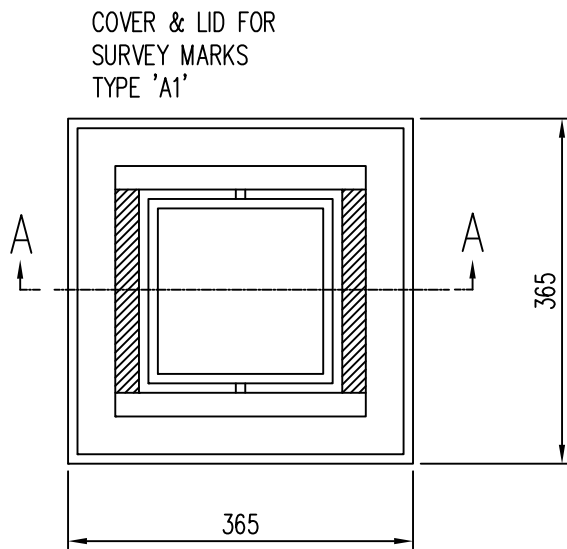

COVER & LID FOR SURVEY MARKS TYPE 'A1'

PLAN OF SURROUND

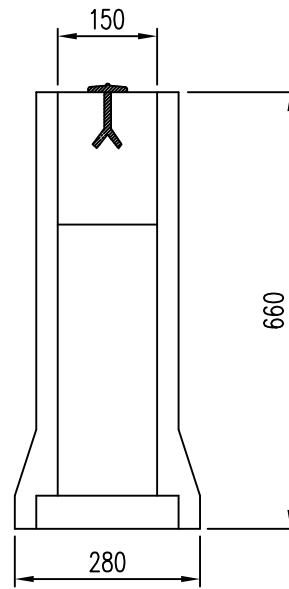

BASE BLOCK SECTION A-A

CAST IRON OR DOUBLE GALVANISED LID FOR SURVEY MARKS IS STANDARD AS SET OUT BY THE DEPT. OF CROWN LANDS & SURVEY

300mm. MIN. OF STEEL CHAIN FIRMLY ATTACHED TO BOTH COVER & LID

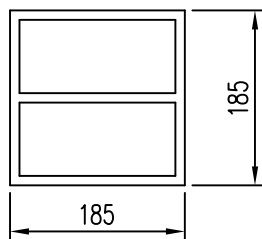

COVER DETAILS

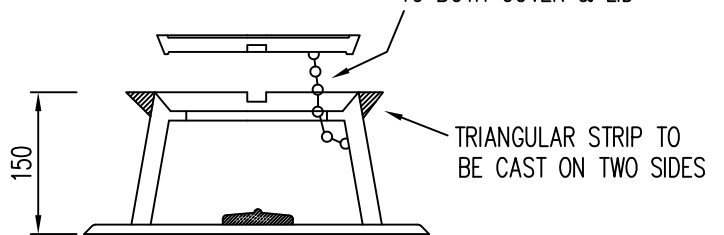

COVER SECTION A-A

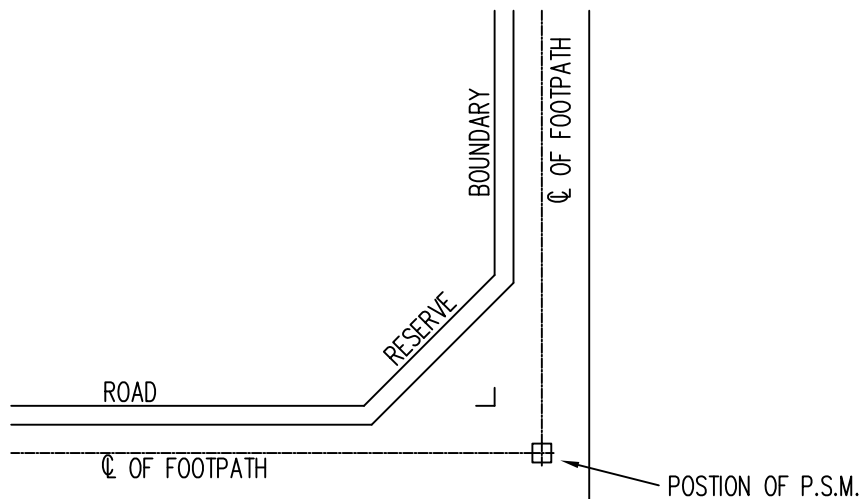

PLAN

CITY OF CASEY

PERMANENT SURVEY MARK

MANAGER OF ENGINEERING & ENVIRONMENTAL SERVICES
LAST UPDATE 09.11.2012

AMENDMENTS: GENERAL UPGRADE

S-800

V2

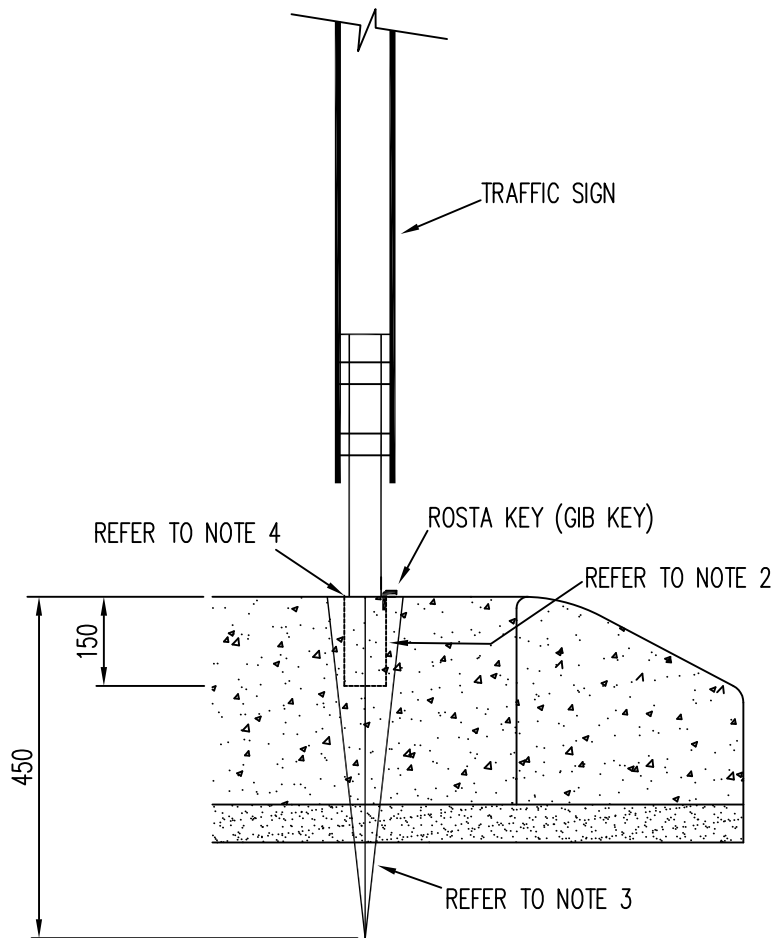

NOTES

1. SIGNS ARE TO BE INSTALLED IN ACCORDANCE WITH AS 1742
2. SLEEVE IS TO BE CONCRETED INTO THE TRAFFIC ISLAND
3. LOC-SOCKET SPIKE IS TO BE DE NEEFE OR APPROVED EQUIVALENT
4. SLEEVE TO BE APPROX 15mm ABOVE LEVEL OF CONCRETE ISLAND

CITY OF CASEY

LOC-SOCKET SPIKE AND WEDGE DETAIL
FOR SIGN POSTS

AMENDMENTS: GENERAL UPGRADE

MANAGER OF ENGINEERING &
ENVIRONMENTAL SERVICES
LAST UPDATE 09.11.2012

S-801

V1

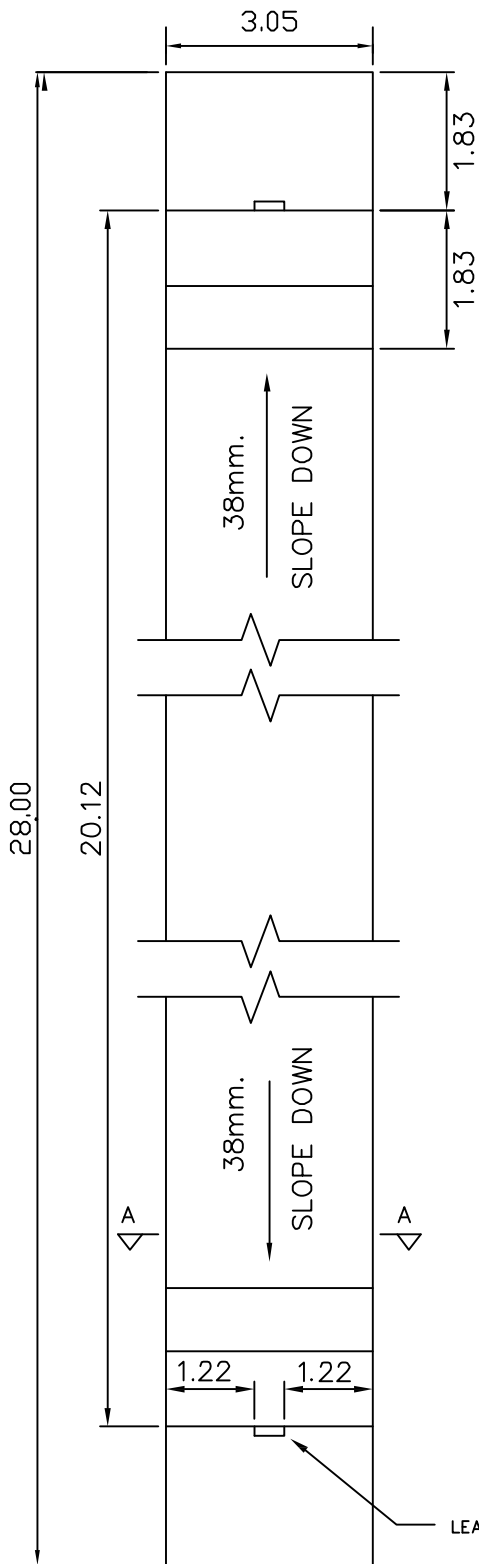

PLAN

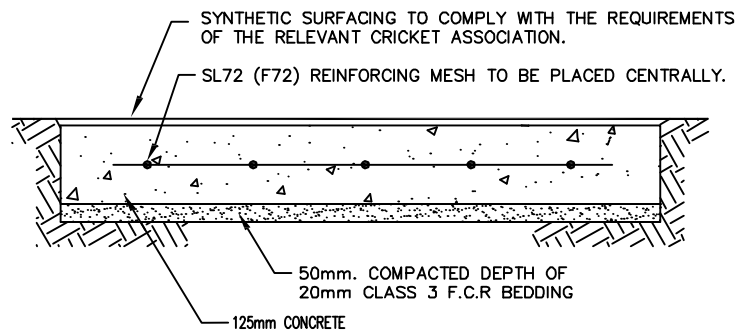

SECTION A-A

LEAVE OPENING 300X75mm FULL DEPTH OF CONCRETE AT EACH END

CITY OF CASEY

CONCRETE CRICKET PITCH
SYNTHETIC GRASS SURFACE

MANAGER OF ENGINEERING &
ENVIRONMENTAL SERVICES
LAST UPDATE 09.11.2012

AMENDMENTS: GENERAL UPGRADE

S-801A

V4

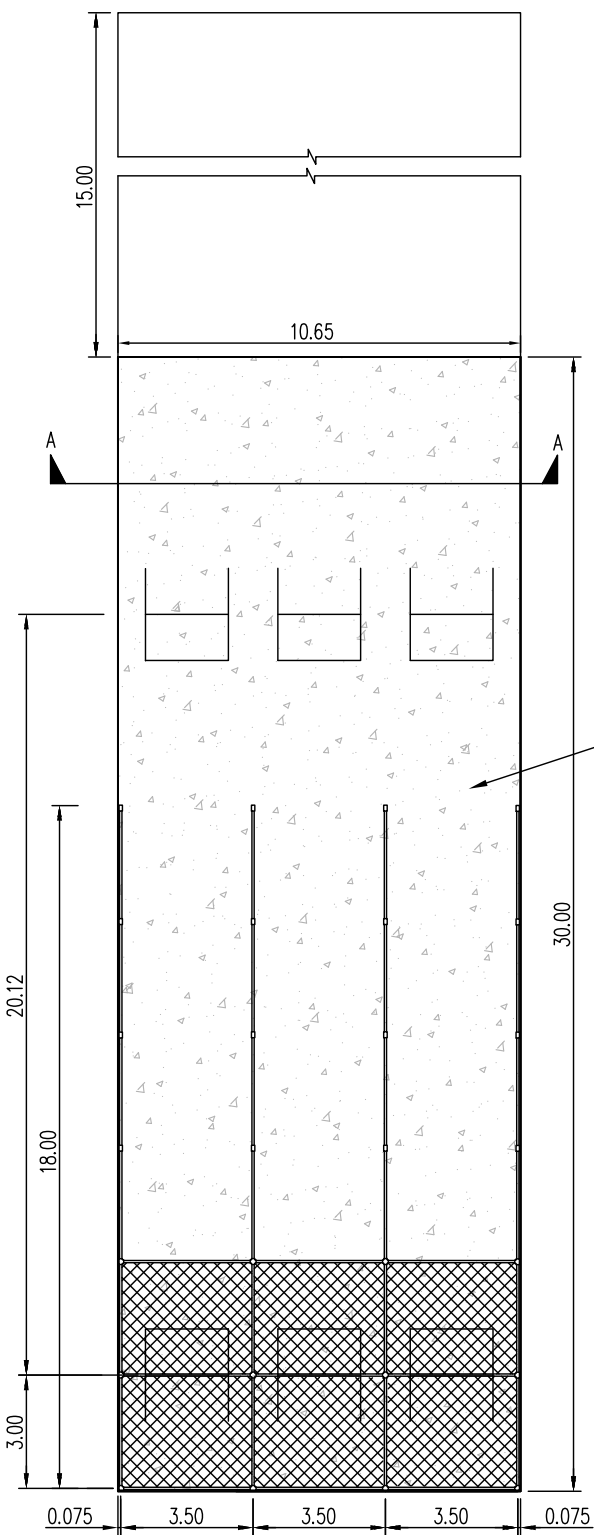

CRICKET NETS SYNTHETIC GRASS SURFACE
SCALE 1:200

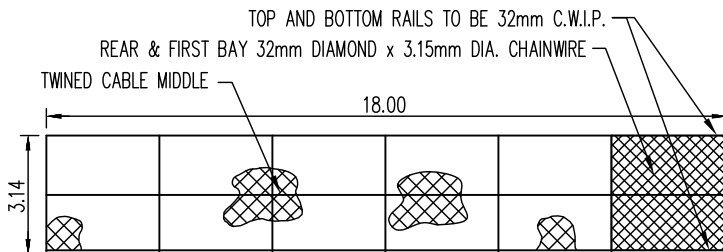

CRICKET NETS SIDE VIEW
SCALE 1:200

FOOTING

CONCRETE FOOTINGS MIN. 230mm DIA. x 600mm, DEEP
CONCRETE STRENGTH F'C = 25MPa.

POSTS

AT 3.0M CENTRES
END & CORNER 50 mm. G.W.I.P., OTHERS 40mm

RAILS

TOP & BOTTOM RAILS TO BE 32mm C.W.I.P.

MESH

REAR & FIRST BAY 32mm DIAMOND x 3.15mm DIA. CHAINWIRE
BALANCE 50mm DIAMOND x 3.15mm DIA. CHAINWIRE

SYNTHETIC SURFACE WITH 125mm CONCRETE BASE

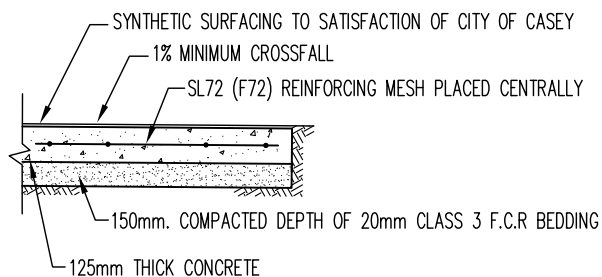

CRICKET NETS SECTION A-A
NOT TO SCALE

NOTES:

1. HEIGHT OF NETS TO BE SET AT 3.14m
2. ROOF SUPPORT TO BE 32mm BLACK POWDERCOATED
3. ALL PIPE AND FITTINGS SHALL BE BLACK POWDERCOATED
4. REAR TWO BAYS ROOFED
5. ALL CHAINWIRE TO BE BLACK PVC COATED
6. 3.15mm TWINED CABLES MIDWAY ON ALL WALLS
7. CONCRETE FOOTINGS 230 DIA X 600 DEEP 25MPa
8. SIDE FENCE AND DIVIDE FENCE TO BE 18m
9. ALL PIPE TO BE MEDIUM GRADE
10. CONCRETE SLAB MUST HAVE 1% CROSSFALL

CITY OF CASEY

CRICKET PRACTICE FACILITY DETAILS
SYNTHETIC GRASS SURFACE

AMENDMENTS: GENERAL UPGRADE

Shah

MANAGER OF ENGINEERING &
ENVIRONMENTAL SERVICES
LAST UPDATE 09.11.2012

S-801B

V5

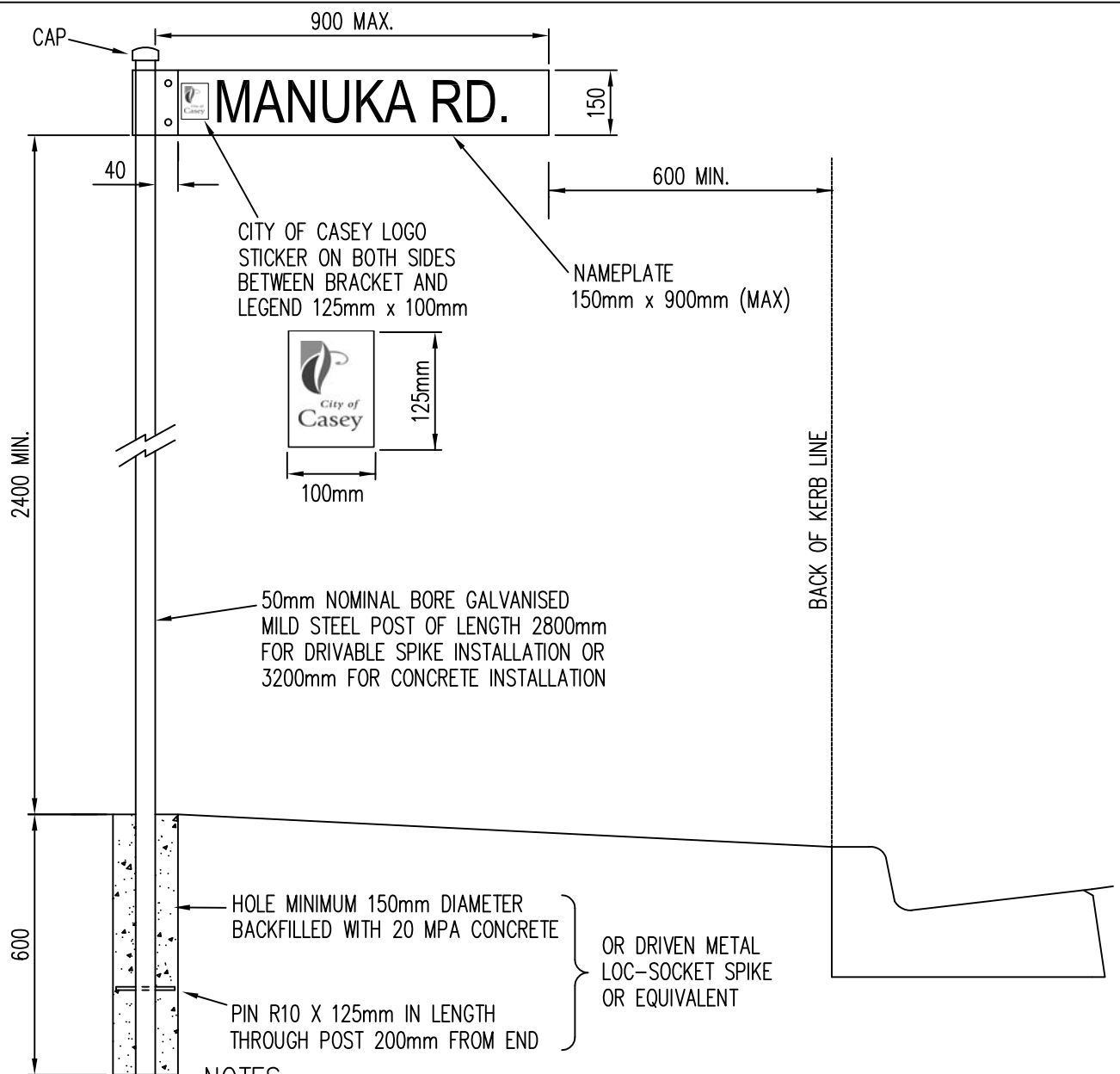

NOTES

1. BASE MATERIAL – EXTRUDED ALUMINIUM BLADE, DE NEEFE G5 OR EQUIVALENT (150 MM HIGH X MAXIMUM LENGTH OF SIGN 900 MM)
2. THE LEGEND SHALL BE 100mm HIGH WITH CLASS C LETTERING (AS 1742-5 1997) UNLESS THE MAXIMUM LENGTH OF SIGN WOULD BE EXCEEDED. IN SUCH CASES THE LETTERING SHALL BE CLASS B (AS 1742-5 1997)
3. A CLEAR DISTANCE OF 40mm SHALL BE LEFT FREE OF LEGEND ON BOTH SIDES OF THE SIGN AT ONE AND THE SAME END
4. THE LEGEND SHALL BE CUT FROM 3M ELECTROCUT FILM OR EQUIVALENT STANDARD GREEN 1176 OVERLAYED ON CLASS 1 BACKGROUND. SCREEN PRINTED OVERLAYS SHALL NOT BE PERMITTED.
5. THE BACKGROUND SHALL BE CLASS 1 WHITE
6. THE SIGN SHALL BE ATTACHED TO THE POLE USING DE NEEFE AL1 6 BRACKETS OR EQUIVALENT. THE USE OF BRACKETS WHICH GRIP THE SIGN ONLY AT THE TOP AND BOTTOM SHALL NOT BE PERMITTED
7. SIGNS TO BE LOCATED IN ACCORDANCE WITH AS (1742.5 1997).

CITY OF CASEY

STREET NAME PLATES

MANAGER OF ENGINEERING & ENVIRONMENTAL SERVICES

LAST UPDATE 09.11.2012

AMENDMENTS: GENERAL UPGRADE

S-803

V3

NOTE
THIS IS A TYPICAL CROSSING PLAN. SLIGHT VARIATIONS MAY OCCUR AFTER INSPECTION AND APPROVAL OF LOCATION BY COUNCIL.

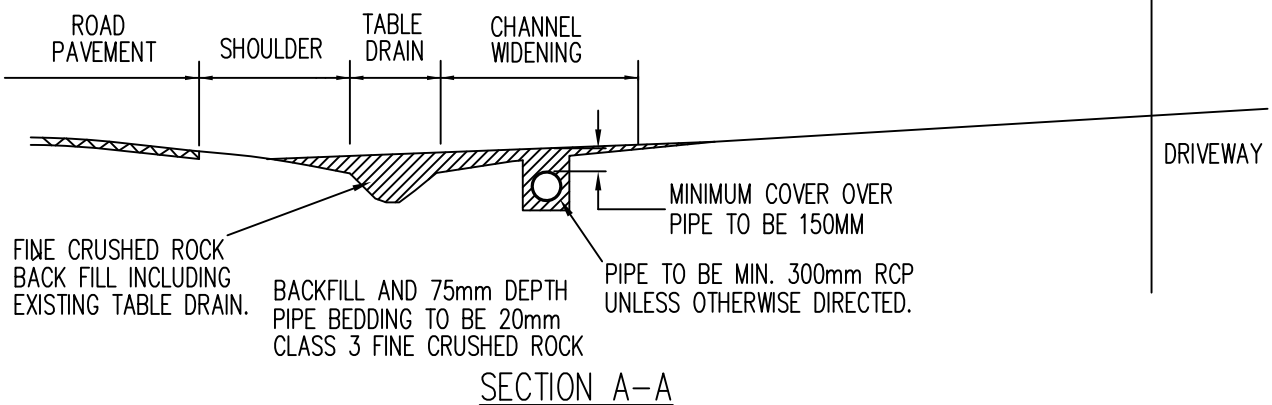
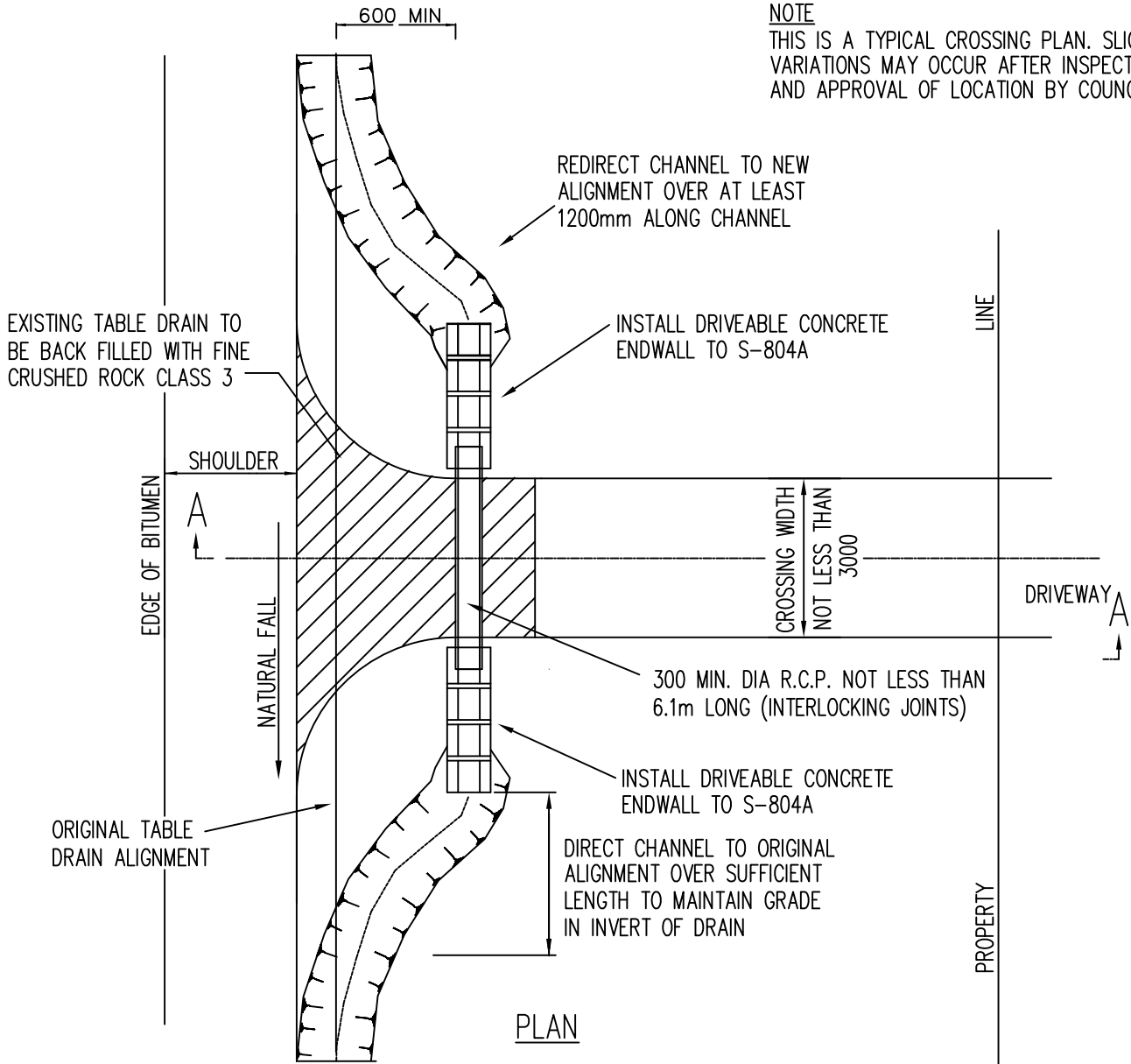

NOTES
1. Driveable Endwalls are only required when pipe under crossing occurs within the clear zone as identified in Ausroads 2009 Part 6 Table 4.1

CITY OF CASEY

**VEHICLE CROSSING
OVER TABLE DRAINS**

[Signature]
MANAGER OF ENGINEERING &
ENVIRONMENTAL SERVICES
LAST UPDATE 09.11.2012

AMENDMENTS: GENERAL UPGRADE

S-804

V2

CROSSING SPECIFICATIONS & CONDITIONS OF APPROVAL FOR NEW DRIVEWAYS IN ESTABLISHED AREAS

Inspections:

An inspection date and time must be booked a minimum of 24 hours prior to concrete being poured. Inspection bookings are taken by Casey's Works & Operations Dept. on (03) 9705 5345.

Removal of existing concrete paving and/or kerb and channel:

Paving – All 75mm thick concrete paving must be removed and replaced to the same thickness as the new crossing. Any paving that is to be removed must be removed to the nearest construction joint either side of the crossing. Any damage to adjoining bays will result in the replacement of those bays at the contractor's cost.

Kerb & channel – Any kerb & channel that is to be removed is to be neatly saw cut at the edge of the modified kerb & channel. If the remaining section of kerb & channel would be shorter than 1.2m in length to the nearest joint, then remove this section of kerb as well and replace to Casey standard. Any damage to adjoining kerb will result in the replacement of those sections at the contractor's cost. When saw cutting the kerb the contractor is to ensure that the asphalt surface is not cut in the process.

Crushed Rock Bedding:

20mm Size, Class 3 crushed rock compacted to a minimum thickness of 50mm. Prior to compaction the crushed rock is to have an optimum moisture content of about 6% which can be achieved by a light sprinkle of water using a garden hose. The bedding rock is to be compacted with a vibrating plate for a minimum of 2 passes per plate width per 50mm layer.

Concrete Paving:

Thickness – Footpath outside crossing 125mm.
Residential Crossing (building line to back of kerb) 125mm.
Industrial Crossing (building line to back of kerb) 150 mm with SL72 (F72) mesh.

Strength – Minimum strength of concrete is to be 25Mpa with a maximum slump of 80mm.

Surface Finish – To be rolled with twin drum mesh roller. Then Light broom finish with trowelled high-lighted edges and joints.

Modified Kerb and Channel:

Thickness – 200mm at Roadside edge; 150mm at Invert of channel; at back of layback match crossing thickness (ie 125mm thick for residential and 150mm thick for industrial).

Strength – Minimum strength of concrete is to be 25Mpa with a maximum slump of 80mm.

Surface Finish – Smooth trowelled rendered surface (render to consist of one part sand, one part cement and one part stone dust).

General Conditions:

1. A minimum of 24 hours notice is required to book an inspection of the works.
2. Weekday works in an arterial road reservation may only be undertaken between the hours of 9:00am and 3:30pm in order to avoid disrupting peak traffic flows.
3. A person conducting works in any road reservation must have in operation a traffic management plan prepared in accordance with the "Road Management Act 2004 – Worksite Safety – Traffic Management – Code of Practice".
4. All crossovers that are to be installed in the road reservation of VicRoads' Declared Main Roads are to be referred to VicRoads for approval and are to be constructed to VicRoads' standards.
5. If there is no existing footpath in the vicinity of the proposed crossing, contact Council's Engineering Department on 9705 5200 for required finished surface levels at the building line.
6. If the proposed crossing is adjacent to your neighbour's crossing, they must be combined to create a double crossing.
7. When widening an existing crossing, the additional section must be dowelled jointed to the existing crossing using 12mm bars x 500mm long @ 600 centres. Dowelled a minimum of 150mm into existing concrete crossing.
8. Once a new crossing is installed any redundant crossing must be removed unless it can be satisfactorily demonstrated that there is a need to access the property at another point.
9. If the proposed crossing is to be built over a water tapping, a cast iron or approved surface inspection box is to be cast into the concrete. Also to gain access to the valve, a 100mm PVC spindle protection sleeve is to be fitted from the water main to the box.
10. If a crossing is to be built over a house drain connection, the inspection tee joint must be extended so that the screwed cap is 150mm below the finished surface of the crossing. A cast iron or approved surface inspection box is to be cast into the concrete and a 225mm dia. by 300mm high PVC sleeve must be provided around the screwed cap.
11. If the crossing is to be built over a side entry drainage pit a heavy duty grate and frame must be fitted to match the new crossing levels. Otherwise the crossing shall be repositioned a minimum of 1m offset from the existing side entry drainage pit.
12. If there is a stormwater drainage junction pit behind the kerb (not catching water from the road) a medium duty cast iron manhole cover and frame or an approved equivalent must be fitted to match the new crossing levels. Otherwise 1m offset with barrier kerb and channel type crossover. (**In industrial areas Terra Firma fibreglass type or equivalent pit covers must be used**).
13. If an **electricity pole** in the vicinity of the proposed crossing there must be a minimum clearance of 1m.

NOTES

1. REINFORCEMENT, SL81 (F81) UNLESS OTHERWISE SPECIFIED, SHALL BE CONTINUOUS AROUND CORNERS AND LOCATED AS SHOWN.
CLEAR COVER OF 50mm MIN.,
LAPS :FABRIC 300mm,
BARS 25 x BAR DIAMETER MIN.
2. DISTRIBUTION BARS 12 DIA AT 200 CENTRES
3. CONCRETE SHALL BE NORMAL – CLASS N32 STANDARD STRENGTH GRADE OR HIGHER COMPLYING WITH REQUIREMENTS OF AS 1379.
EXPOSURE CLASSIFICATIONS UP TO AND INCLUDING B1.
4. EXPOSED EDGES SHALL HAVE 20 x 20 CHAMFERS
5. RAILS WITHIN SECTION "L" SHALL BE EVENLY SPACED.
6. RAILS ARE 60.3 DIAMETER GALVANISED TUBES 5.4mm THICK. THESE ARE TO BE GROUTED INTO THE SLOTS IN THE WALLS.
7. SLOPE OF ENDWALL TO MATCH BATTER SLOPE. MAXIMUM SLOPE 1 IN 4
8. ENDWALLS SHALL BE CONSTRUCTED IN ACCORDANCE WITH THE RELEVANT PROVISIONS OF AS 3600.
9. ACCEPTABLE PRECAST DRIVEABLE ENDWALLS ARE AVAILABLE TO SUIT PIPE SIZES FROM 300mm TO 600mm FROM VICPITS PTY LTD
VIC PITS PTY LTD,
2 REEVES COURT
BREAKWATER VIC. 3219

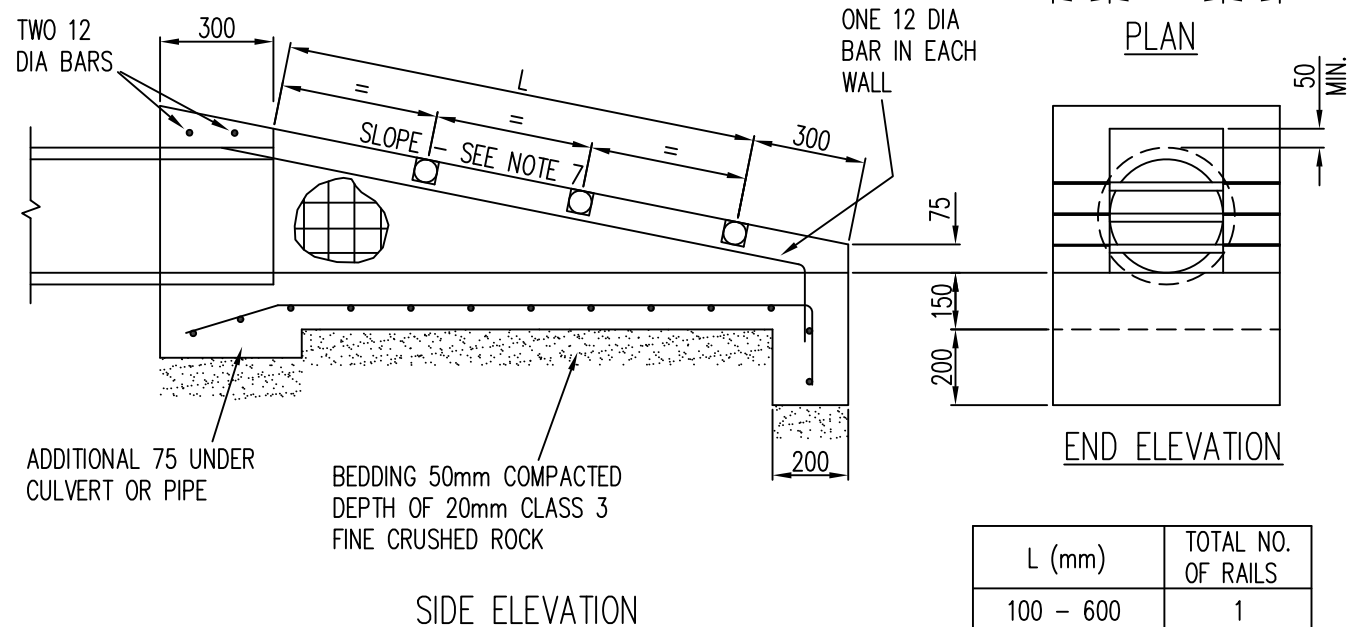

CITY OF CASEY

VICROADS TYPE DRIVEABLE ENDWALL

Robert

MANAGER OF ENGINEERING &
ENVIRONMENTAL SERVICES

LAST UPDATE 09.11.2012

S-804A

AMENDMENTS:

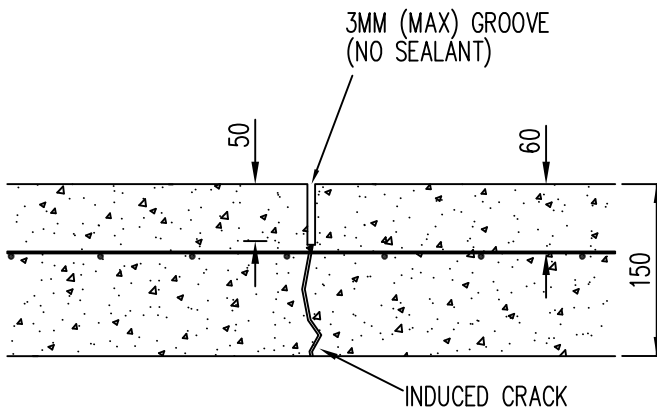

INTERMEDIATE CONTRACTION JOINT DETAILS
SPACING 4M (MAX)

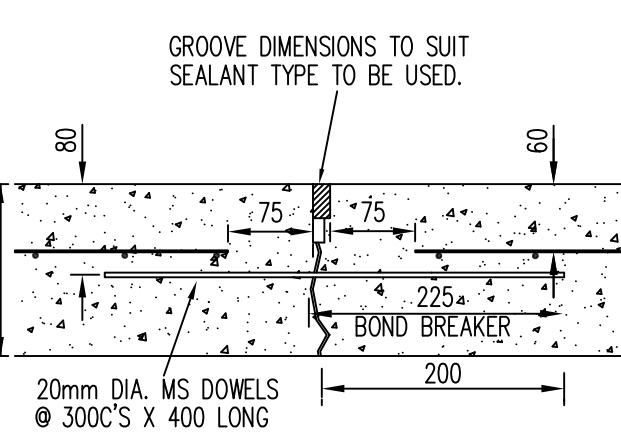

"END" CONTRACTION JOINT DETAILS
SPACING 12M (MAX)

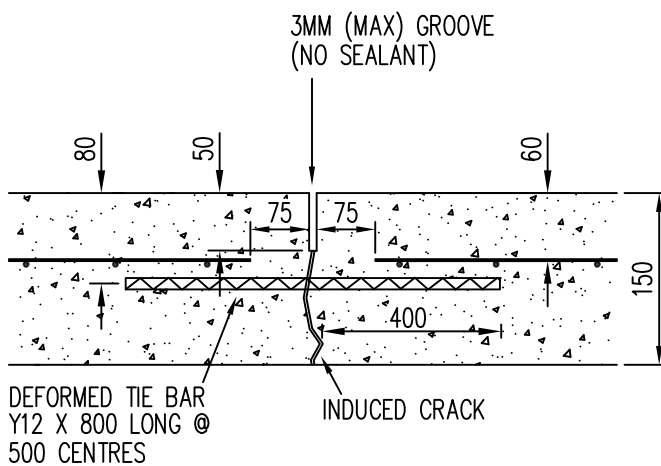

TIED JOINT DETAILS

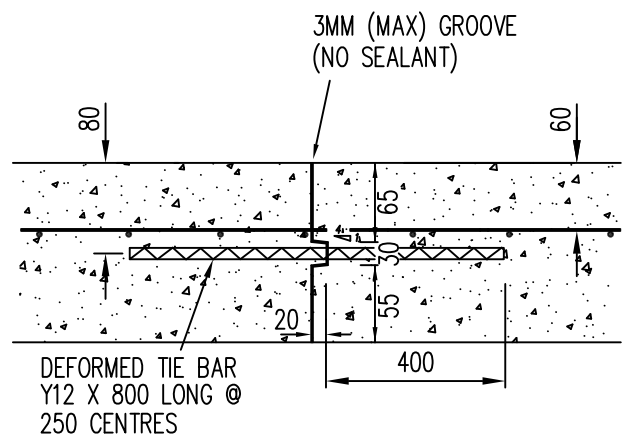

CONSTRUCTION JOINT DETAILS

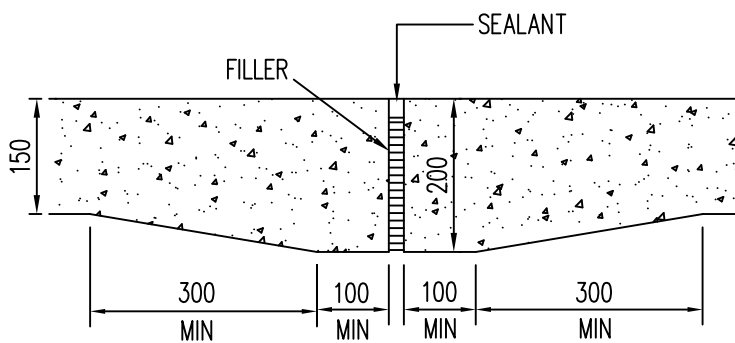

ISOLATION JOINT DETAILS

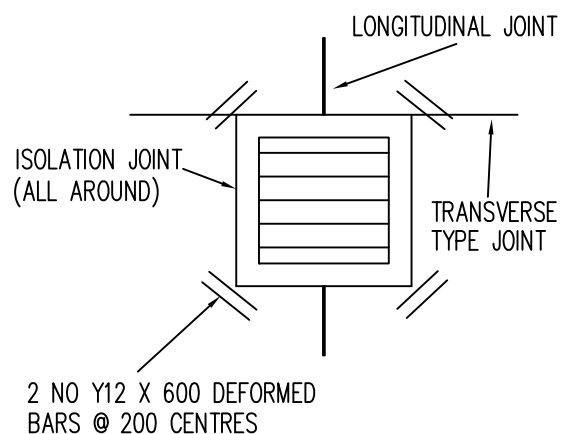

TYPICAL JUNCTION PIT JOINTING

CITY OF CASEY

CONCRETE SLAB JOINTING DETAILS

AMENDMENTS: GENERAL UPGRADE

MANAGER OF ENGINEERING & ENVIRONMENTAL SERVICES
LAST UPDATE 09.11.2012

S-805

V2

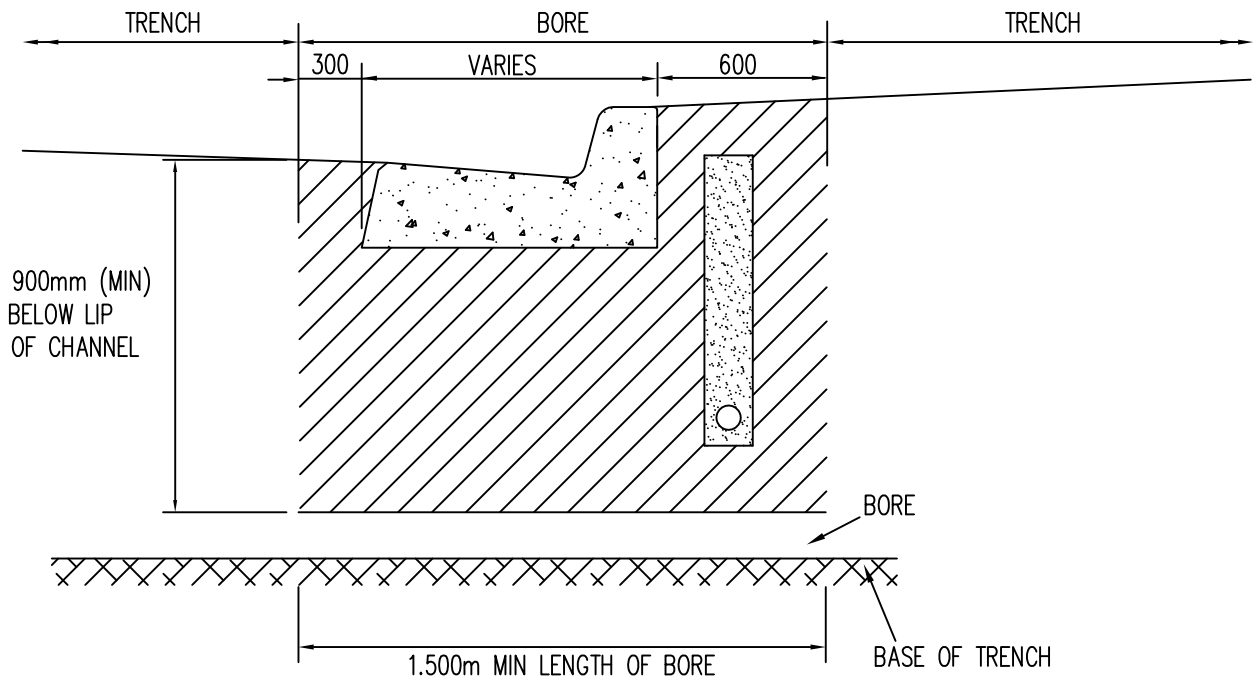

BORING UNDER KERB & CHANNEL

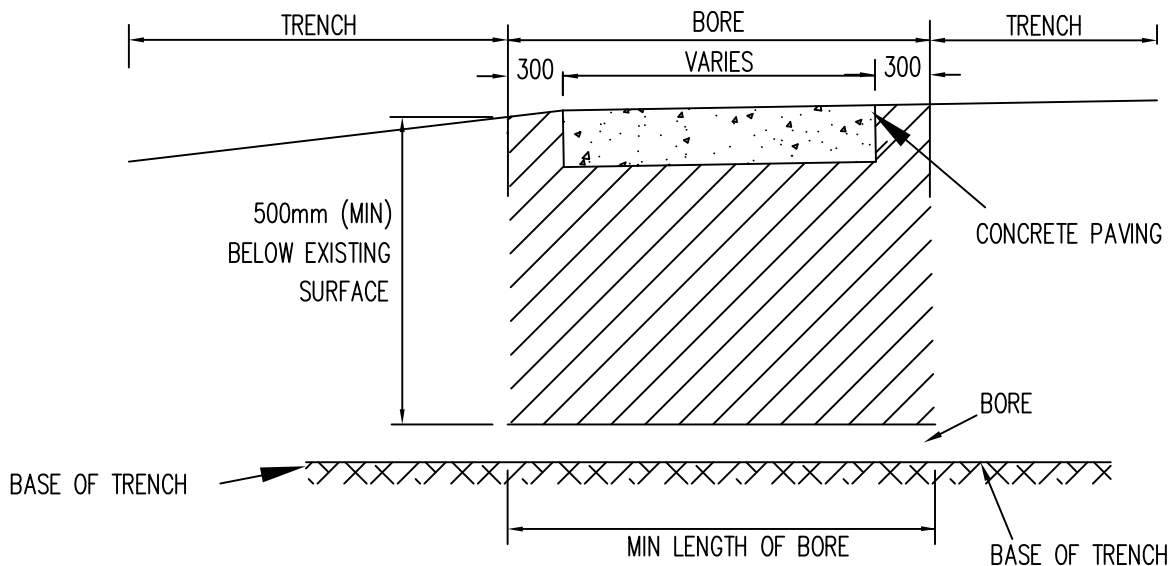

BORING UNDER CONCRETE PAVING

CITY OF CASEY

CONDITIONS FOR INSTALLATIONS OF SERVICES
UNDER KERB AND CHANNEL AND CONCRETE PAVING
BY THRUST BORING

Robert

MANAGER OF ENGINEERING &
ENVIRONMENTAL SERVICES
LAST UPDATE 09.11.2012

AMENDMENTS: GENERAL UPGRADE

S-807

V2

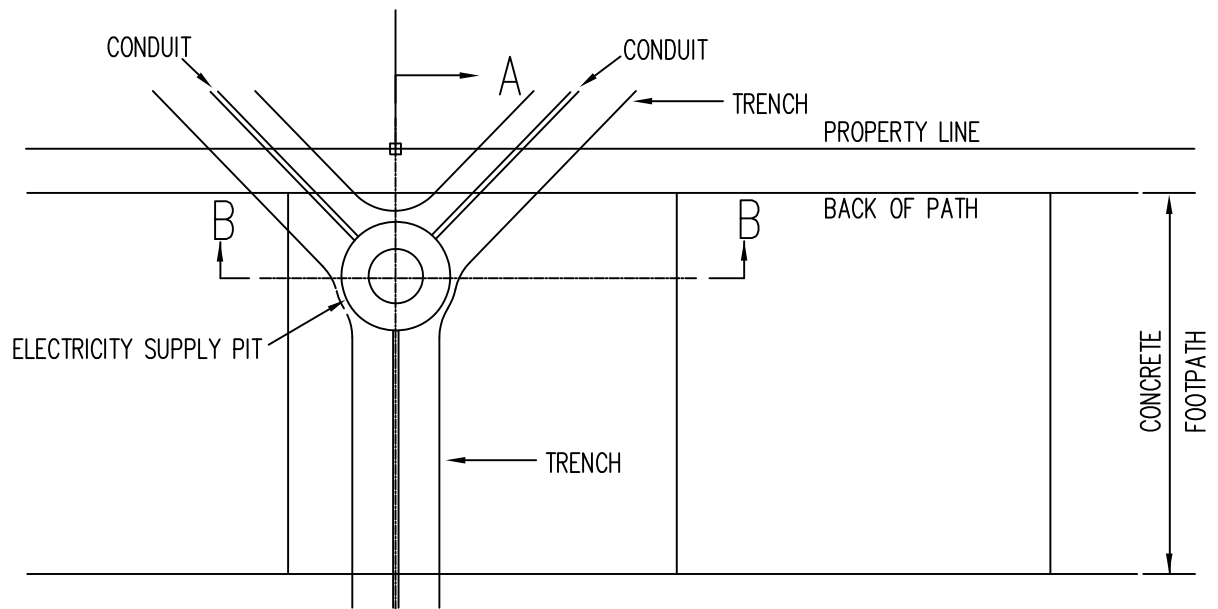

PLAN

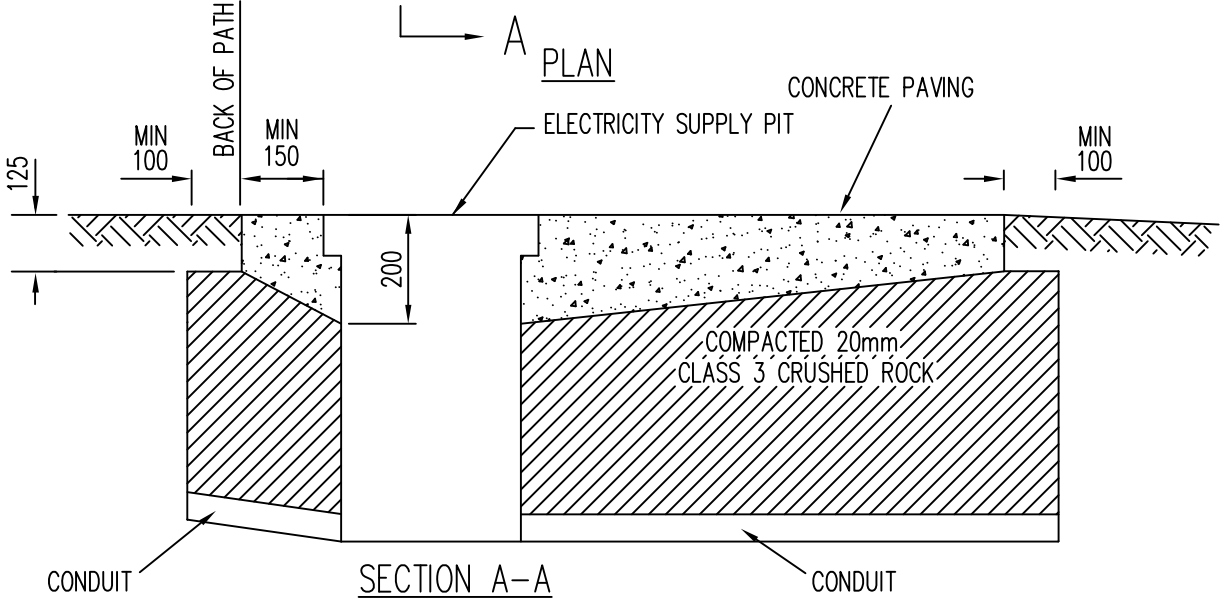

SECTION A-A

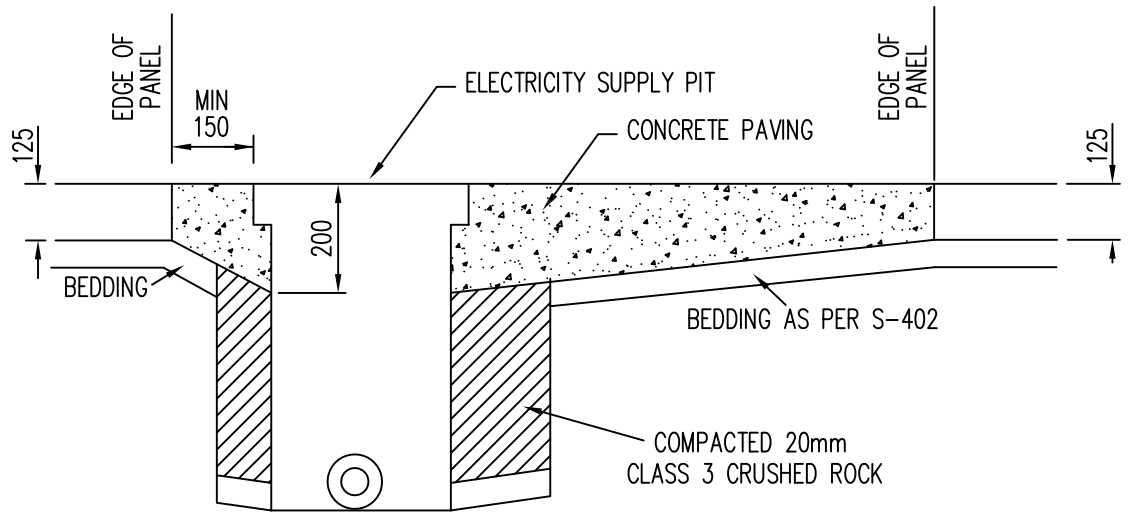

SECTION B-B

CITY OF CASEY

BACKFILLING OF UNDERGROUND ELECTRICITY SUPPLY PITS

MANAGER OF ENGINEERING &
ENVIRONMENTAL SERVICES

LAST UPDATE 09.11.2012

AMENDMENTS: GENERAL UPGRADE

S-808

V2

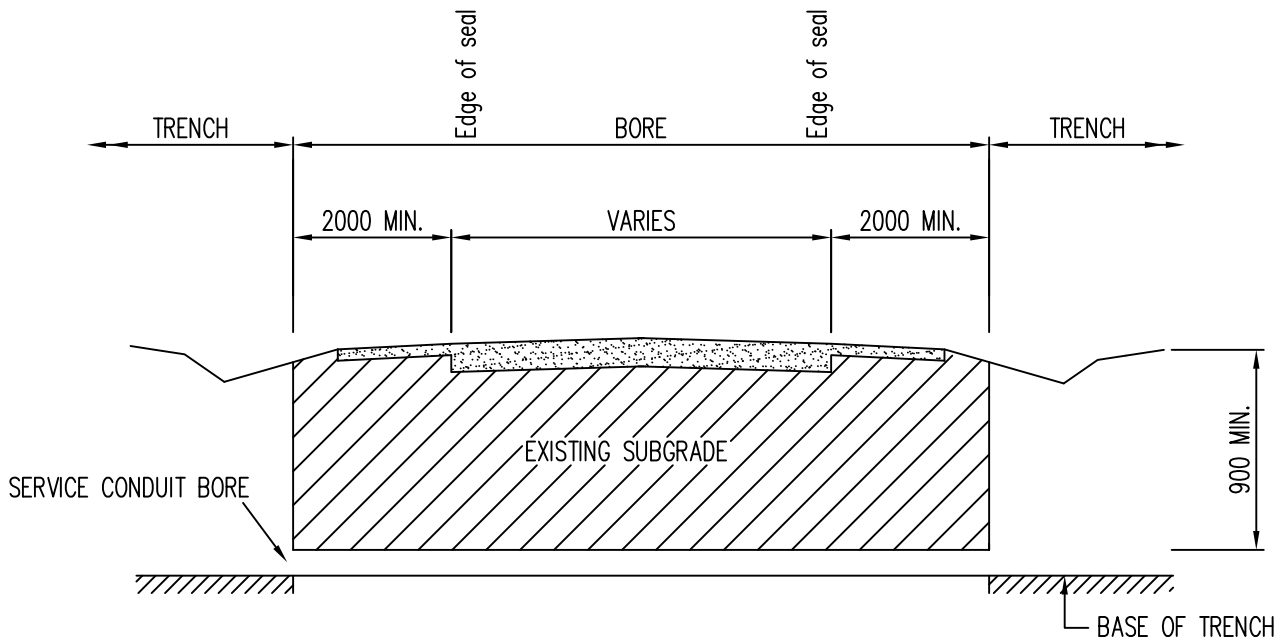

BORING UNDER UNKERBED SEALED PAVEMENT
NOT TO SCALE

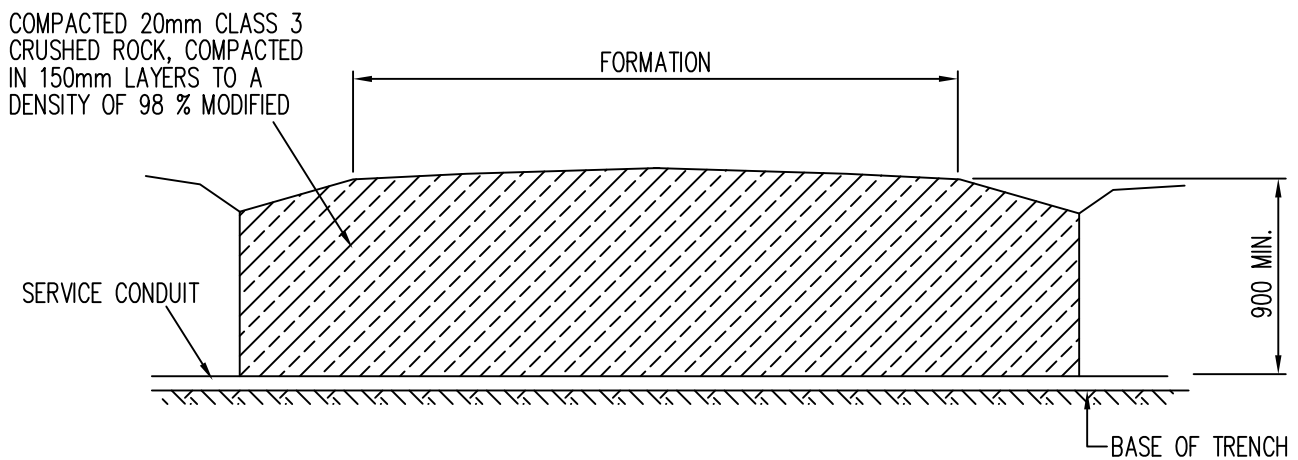

BACKFILLING REQUIREMENTS FOR OPEN TRENCHING UNDER
UNSEALED ROAD PAVEMENT
NOT TO SCALE

CITY OF CASEY

CONDITIONS FOR INSTALLATIONS OF SERVICES
UNDER UNSEALED ROAD PAVEMENT
WITHOUT KERB AND CHANNEL

AMENDMENTS: GENERAL UPGRADE

MANAGER OF ENGINEERING &
ENVIRONMENTAL SERVICES
LAST UPDATE 09.11.2012

S-809

V2

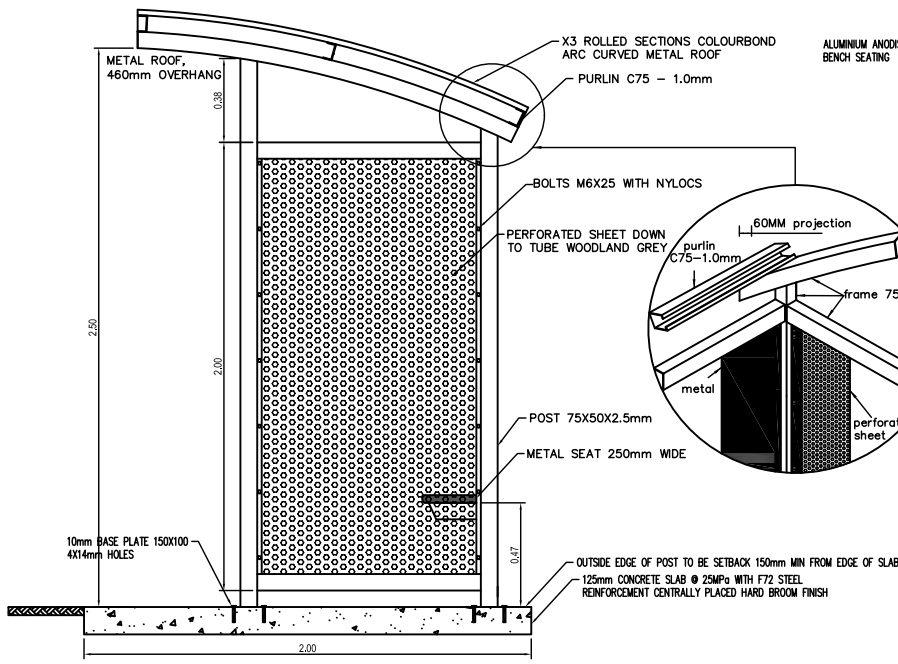

COACHES BOX SIDE ELEVATION

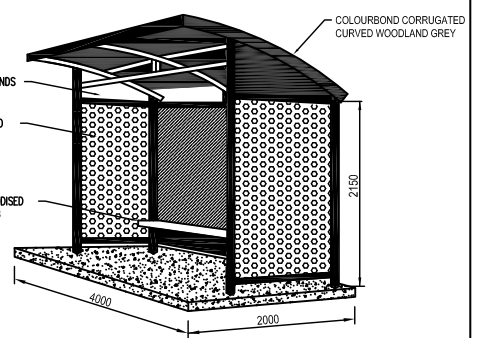

COLOR-COLOURBOND IRONSTONE BLACK
COACHES BOX FRAME COMPETITION SINGLE BENCH SEAT

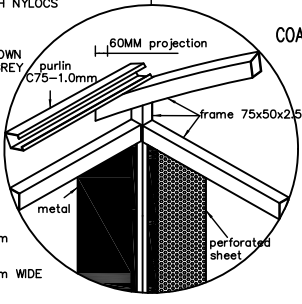

- NOTES**
MATERIAL OF FRAME:
 • 75X50X2.5 GALVANISED
 • 1.95mm PERFORATED SHEET FOR SIDES
 • 1.95mm GALVANISED SHEET FOLDED SECTIONS BACK X3 OFF

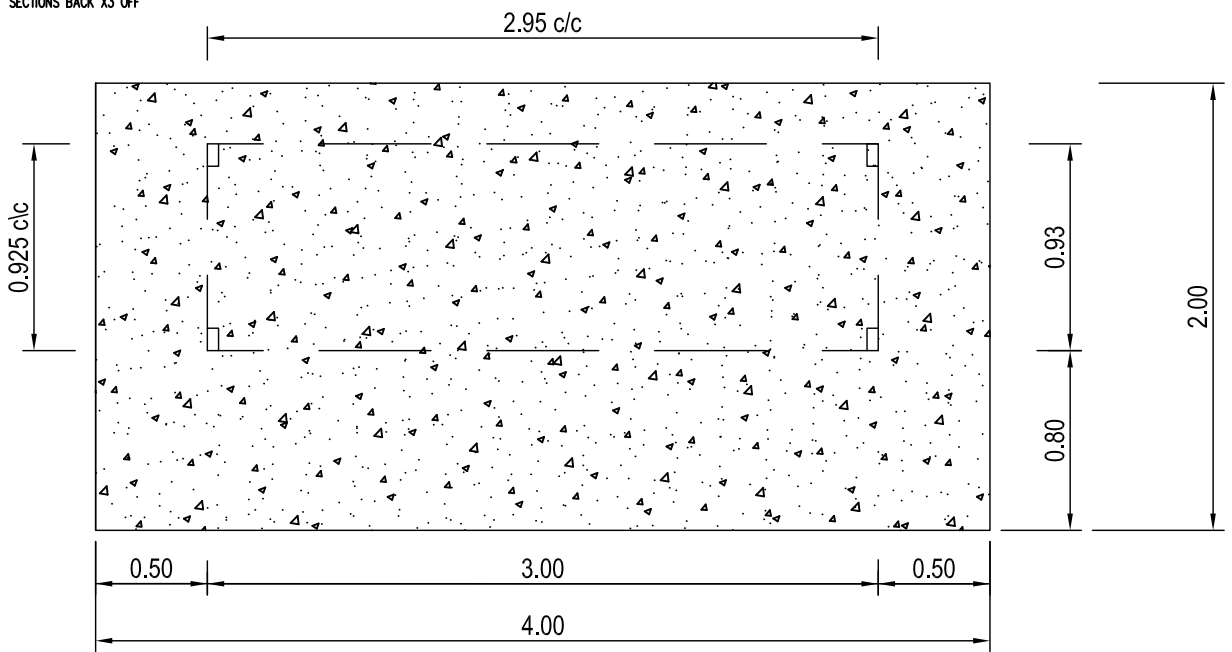

CONCRETE SLAB PLAN VIEW

CITY OF CASEY

COACHES BOX

Shahab

MANAGER OF ENGINEERING &
 ENVIRONMENTAL SERVICES
 LAST UPDATE 09.11.2012

AMENDMENTS: GENERAL UPGRADE

S-815

V3

LANDSCAPING DETAILS

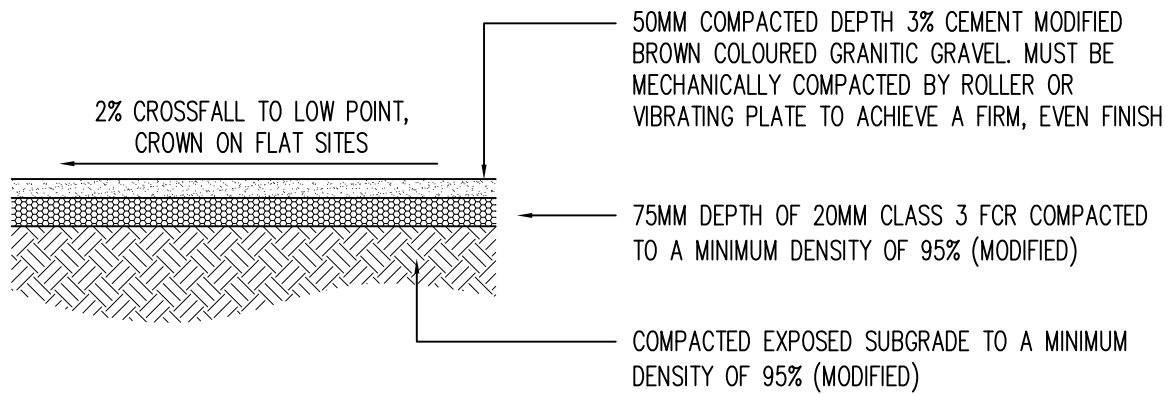

TYPICAL CROSS SECTION FOR
GRANITIC GRAVEL PAVEMENT

NOTES

1. 3% CEMENT MODIFIED GRANITIC GRAVEL MATERIAL TO BE THOROUGHLY AGITATED AT QUARRY PRIOR TO INSTALLATION.
2. SAMPLE OF GRANITIC MATERIAL TO BE APPROVED BY COUNCIL OFFICER PRIOR TO USE AND A COPY OF BATCH DELIVERY DOCKET FOR PROOF OF SAME DAY DELIVERY.
3. MATERIAL IS NOT TO BE STORED ON SITE FOR MORE THAN 24 HOURS.

CITY OF CASEY

HARD LANDSCAPING
GRANITIC GRAVEL PAVEMENT DETAIL

MANAGER OF ENGINEERING &
ENVIRONMENTAL SERVICES
LAST UPDATE 09.11.2012

AMENDMENTS:

S-1001

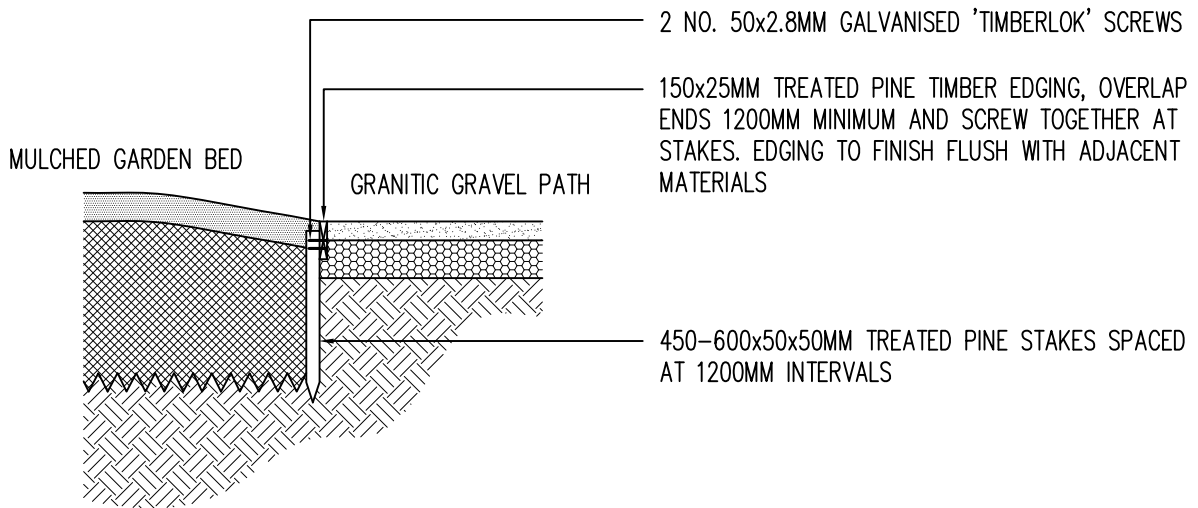

TYPICAL CROSS SECTION
FOR TIMBER EDGE

NOTES

1. NO STEEL PICKETS TO BE USED.
2. SAW CUT INTO 50% THICKNESS AT 10-20MM INTERVALS TO ACCOMODATE CURVES.
3. SUITABLE RECYCLED PLASTIC EDGING MAY BE CONSIDERED.

CITY OF CASEY

HARD LANDSCAPING
TIMBER EDGE DETAIL

MANAGER OF ENGINEERING &
ENVIRONMENTAL SERVICES
LAST UPDATE 09.11.2012

AMENDMENTS:

S-1002

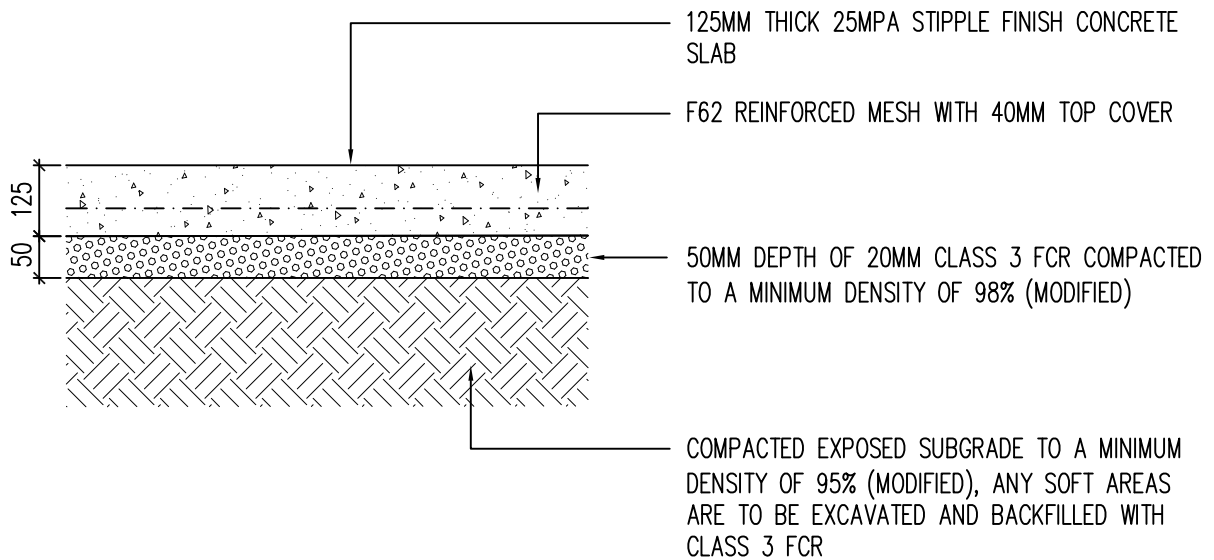

TYPICAL CROSS SECTION
FOR SHED SLAB

NOTES

1. TYPICAL SLAB DETAIL FOR SHEDS UP TO A 3 X 3M MAXIMUM SIZE, ANYTHING ABOVE THIS WILL REQUIRE STRUCTURAL ENGINEERING COMPUTATIONS.

CITY OF CASEY

HARD LANDSCAPING
SHED SLAB DETAIL

MANAGER OF ENGINEERING &
ENVIRONMENTAL SERVICES
LAST UPDATE 09.11.2012

AMENDMENTS:

S-1003

TO PROMOTE LATERAL ROOT GROWTH THE PLANTING HOLE SHALL BE NO LESS THAN TWO TIMES THE DIAMETER OF THE ROOT BALL AND ONLY ACCEPTABLE IF DUE TO SPACE RESTRICTIONS, OTHERWISE ALLOW FOR NO LESS THAN THREE TIMES THE DIAMETER OF THE ROOT BALL. SLOPE ALL SIDES AT 45 DEGREES

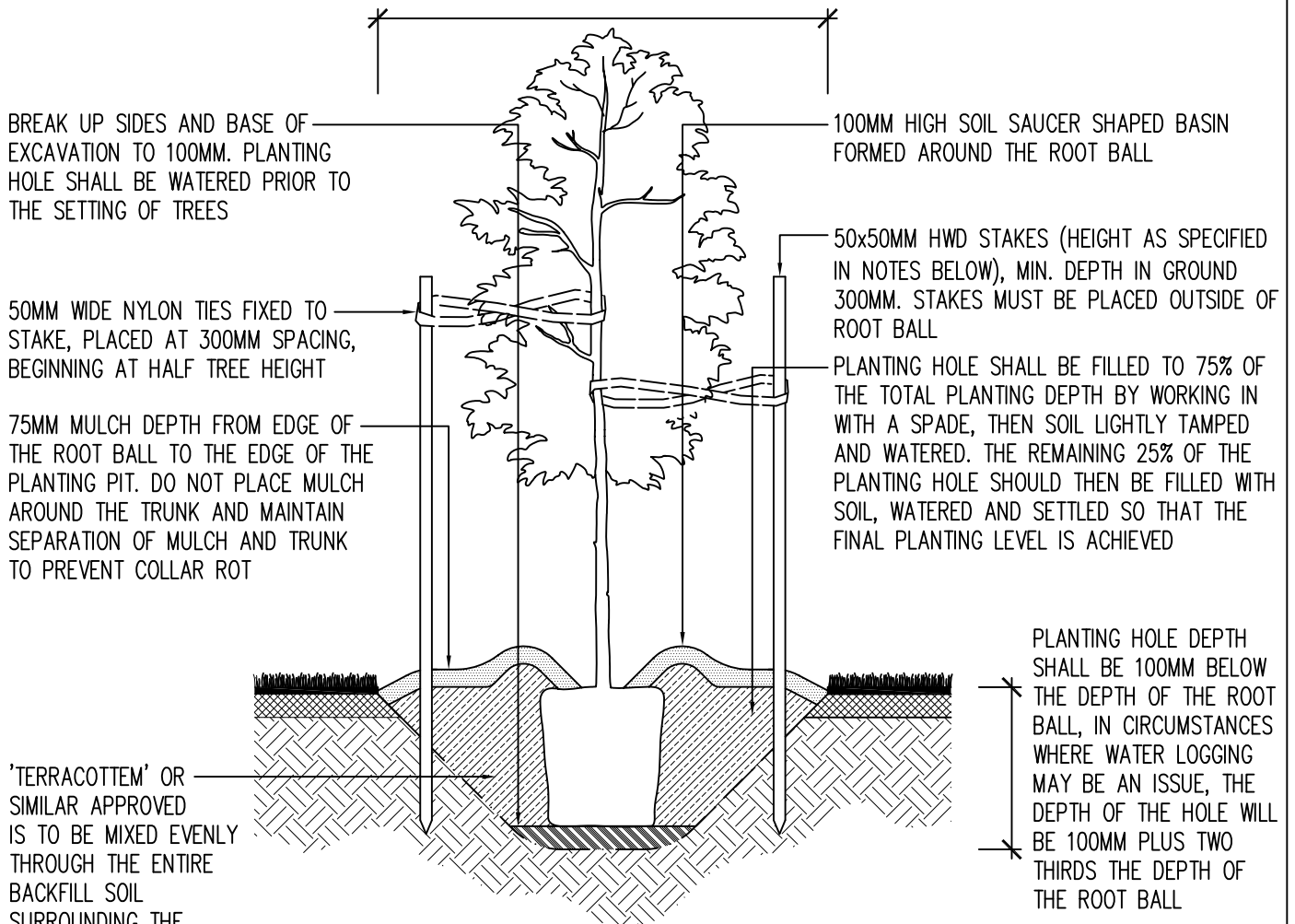

TYPICAL CROSS SECTION FOR
ADVANCED TREE PLANTING

NOTES

1. ENSURE ALL LABELS, WIRES, TWINE AND OTHER BINDING MATERIALS ARE REMOVED FROM PLANTING MATERIAL, INCLUDING ROOT BALLS PRIOR TO BACKFILLING.
2. WATER IMMEDIATELY FOLLOWING PLANTING, SAUCER TO BE FILLED TWICE.
3. SITE TO BE LEFT CLEAN AND TIDY ON COMPLETION OF PLANTING, REMOVE WEEDS AND BUILDING SPOIL FROM TREE PLANTING ZONE.
4. FOR TREES BETWEEN 1.5–2.5M HIGH SUPPLY STAKES AT 1800MM HEIGHT, TREES BETWEEN 2.5–3.5M HIGH SUPPLY STAKES AT 2100MM HEIGHT, TREES ABOVE 3.5M SUPPLY STAKES AT 2400MM HEIGHT.
5. ANY VARIATIONS TO THIS DETAIL TO BE SUBMITTED FOR APPROVAL PRIOR TO ANY PLANTING.

CITY OF CASEY

SOFT LANDSCAPING
ADVANCED TREE PLANTING DETAIL

MANAGER OF ENGINEERING &
ENVIRONMENTAL SERVICES

LAST UPDATE 09.11.2012

S-1004

AMENDMENTS:

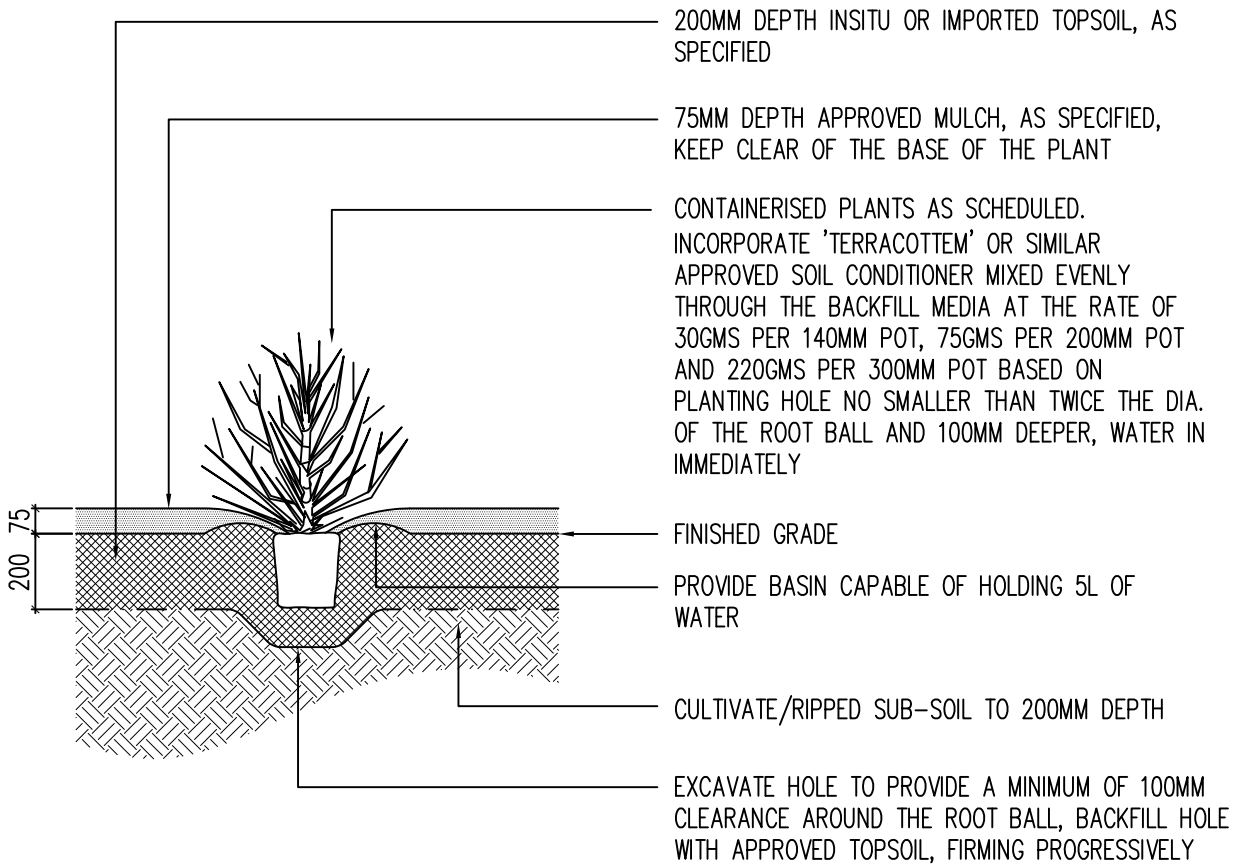

TYPICAL CROSS SECTION
FOR SHRUB PLANTING

NOTES

1. SPRAY ALL WEEDS AND UNWANTED PLANT MATERIAL WITH A SUITABLE HERBICIDE TWO WEEKS PRIOR TO WORKS. REPEAT SPRAY MAY BE NECESSARY.
2. CULTIVATE TO A DEPTH OF 200MM.
3. REMOVE ALL RUBBISH AND DELETERIOUS MATERIALS.
4. FOR LARGE BEDS OR AREAS OF HIGH DENSITY PLANTING 'TERRACOTTEM' OR SIMILAR CAN BE APPLIED TO THE SURFACE AT THE RATE OF 150GMS PER SQ.M AND CULTIVATED EVENLY TO A DEPTH OF 200MM.

CITY OF CASEY

SOFT LANDSCAPING
SHRUB PLANTING DETAIL

MANAGER OF ENGINEERING &
ENVIRONMENTAL SERVICES

LAST UPDATE 09.11.2012

S-1005

AMENDMENTS:

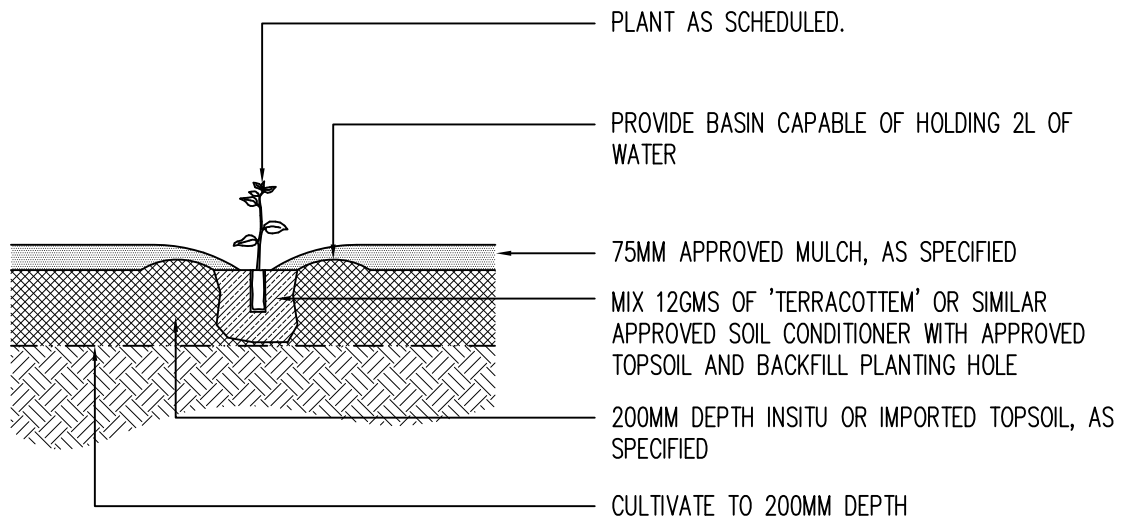

TYPICAL CROSS SECTION
FOR TUBESTOCK PLANTING

NOTES

1. EXCAVATE A PLANTING HOLE NO SMALLER THAN 200x200x200MM.

CITY OF CASEY

SOFT LANDSCAPING
TUBESTOCK PLANTING DETAIL

MANAGER OF ENGINEERING &
ENVIRONMENTAL SERVICES
LAST UPDATE 09.11.2012

AMENDMENTS:

S-1006

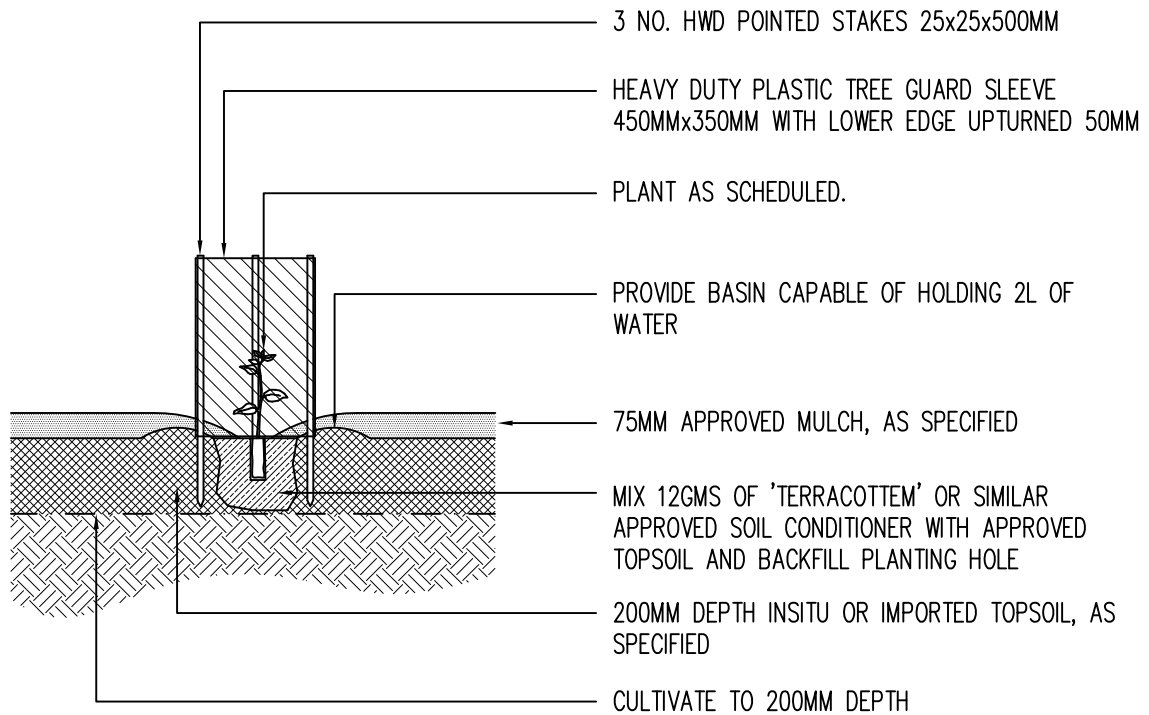

TYPICAL CROSS SECTION FOR TUBESTOCK
PLANTING WITH 3 STAKE GUARD

NOTES

1. EXCAVATE A PLANTING HOLE NO SMALLER THAN 200x200x200MM.

CITY OF CASEY

SOFT LANDSCAPING

TUBESTOCK PLANTING WITH 3 STAKE GUARD DETAIL

MANAGER OF ENGINEERING &
ENVIRONMENTAL SERVICES

LAST UPDATE 09.11.2012

AMENDMENTS:

S-1007

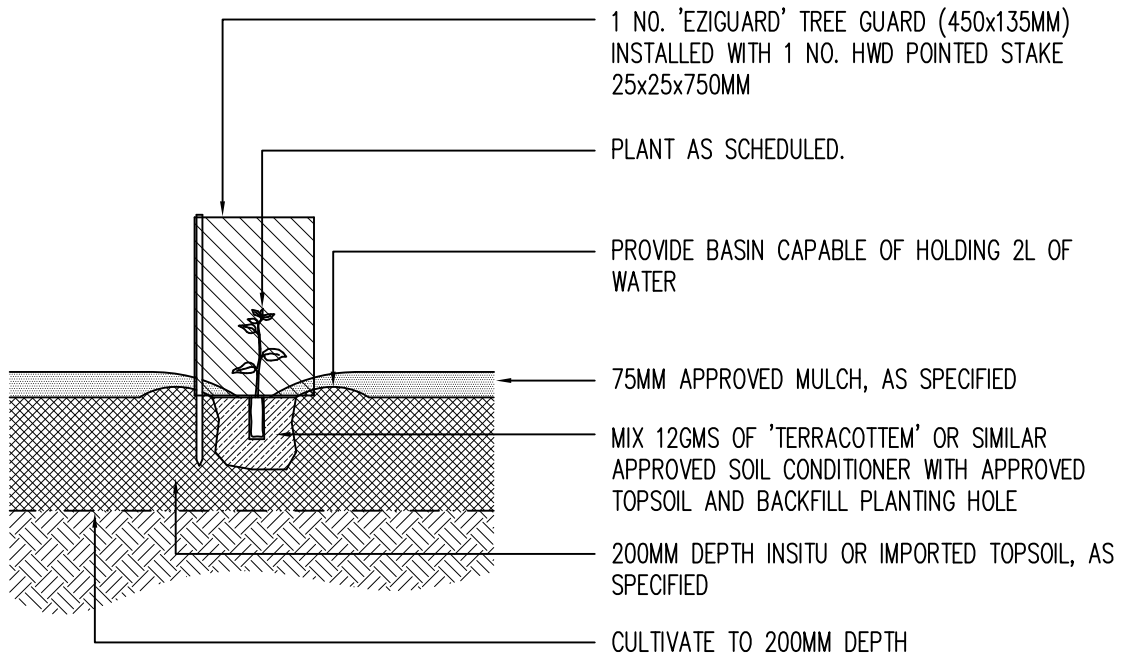

TYPICAL CROSS SECTION FOR TUBESTOCK
PLANTING WITH 1 STAKE GUARD

NOTES

1. EXCAVATE A PLANTING HOLE NO SMALLER THAN 200x200x200MM.

CITY OF CASEY

SOFT LANDSCAPING

TUBESTOCK PLANTING WITH 1 STAKE GUARD DETAIL

MANAGER OF ENGINEERING &
ENVIRONMENTAL SERVICES

LAST UPDATE 09.11.2012

AMENDMENTS:

S-1008

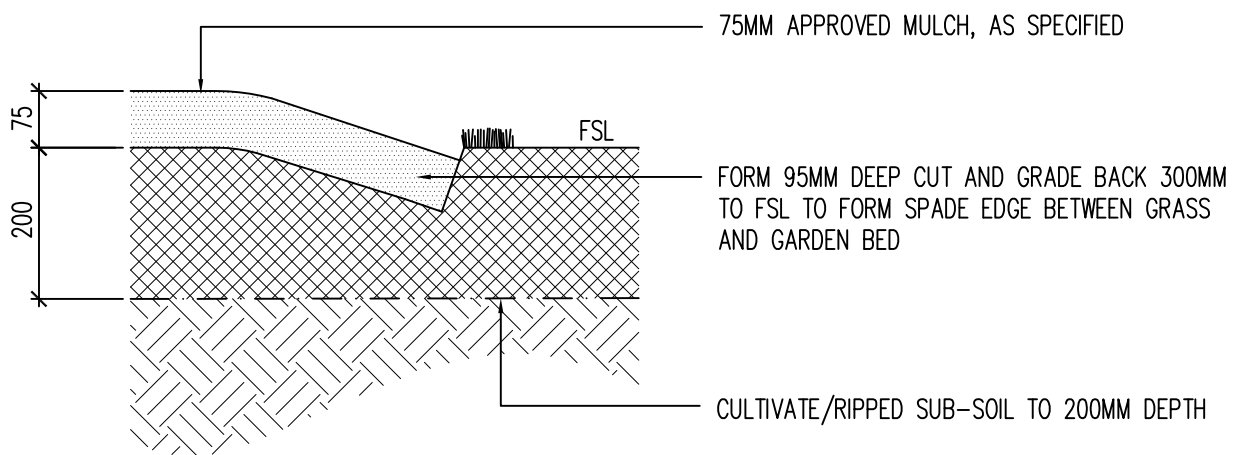

TYPICAL CROSS SECTION
FOR SPADE EDGE

NOTES

1. SPRAY ALL WEEDS AND UNWANTED PLANT MATERIAL WITH A SUITABLE HERBICIDE TWO WEEKS PRIOR TO WORKS. REPEAT SPRAY MAY BE NECESSARY.
2. CULTIVATE WITH MECHANICAL ROTARY HOE TO A DEPTH OF 200MM UNLESS AROUND TREE ROOTS THEN HAND CULTIVATION RESERVED.
3. REMOVE ALL RUBBISH AND DELETERIOUS MATERIALS.

CITY OF CASEY

SOFT LANDSCAPING
SPADE EDGE DETAIL

MANAGER OF ENGINEERING &
ENVIRONMENTAL SERVICES
LAST UPDATE 09.11.2012

AMENDMENTS:

S-1009

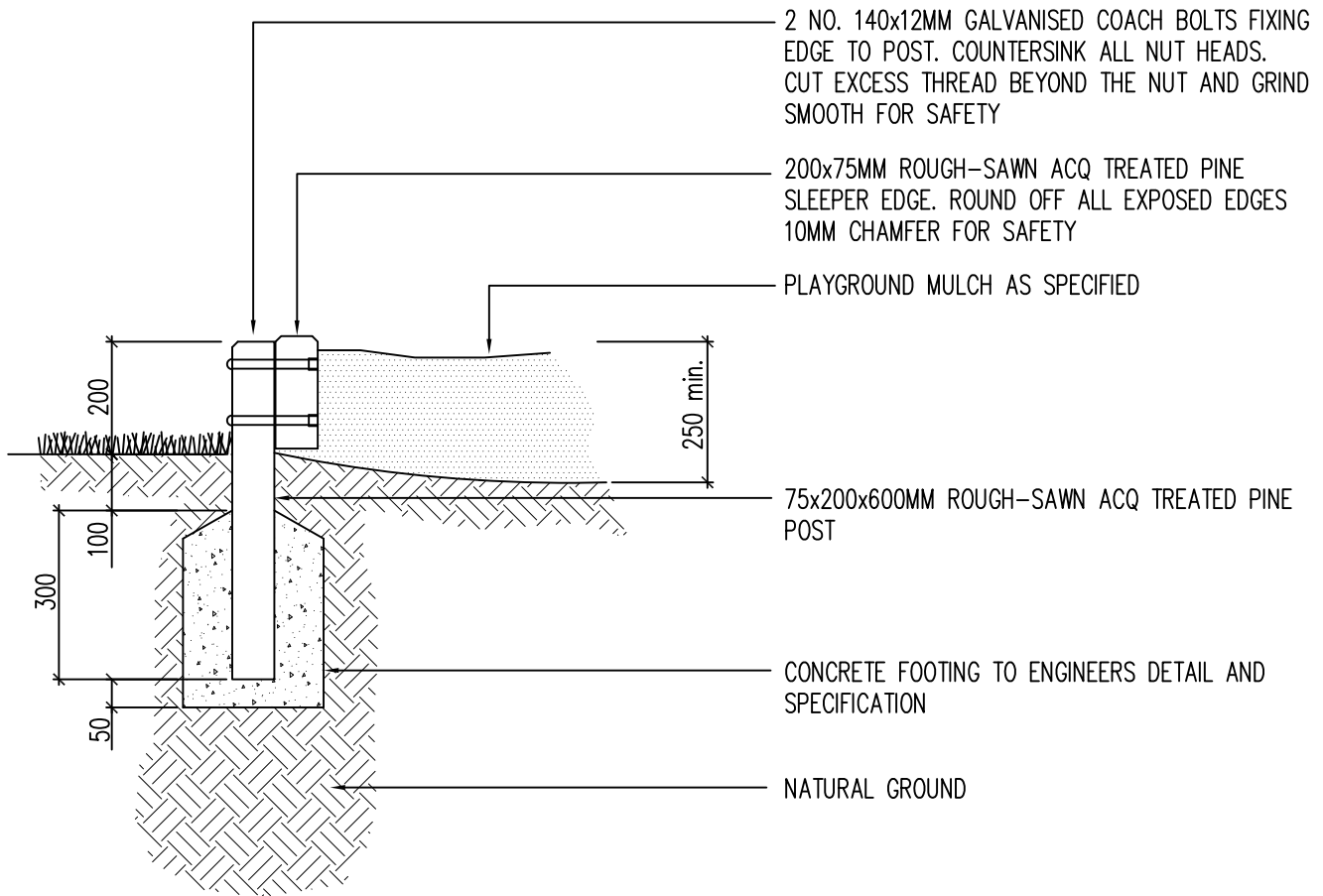

TYPICAL CROSS SECTION FOR
PLAYGROUND TIMBER EDGING

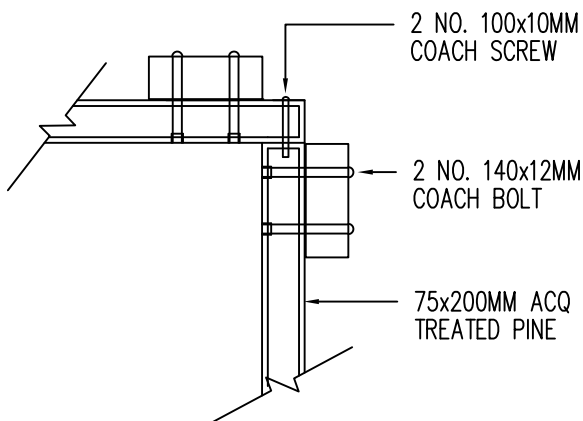

TYPICAL CORNER PLAN FOR
PLAYGROUND TIMBER EDGING

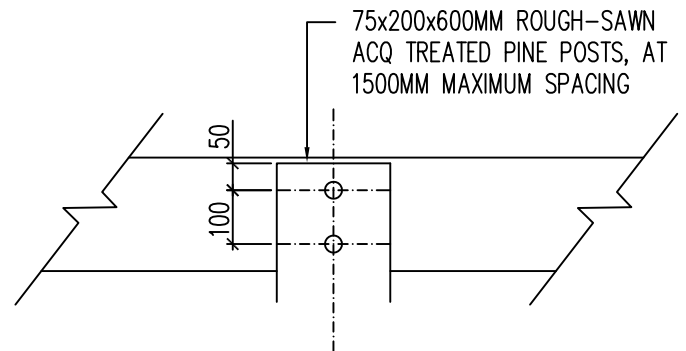

TYPICAL FRONT ELEVATION FOR
PLAYGROUND TIMBER EDGING

NOTES

1. OPTIONAL REPLACEMENT FOR COACH BOLTS: 125MM 14G BUGLE BATTON SCREWS.

CITY OF CASEY

PLAYGROUND ELEMENTS
TIMBER EDGING DETAILS

MANAGER OF ENGINEERING &
ENVIRONMENTAL SERVICES
LAST UPDATE 09.11.2012

AMENDMENTS:

S-1010

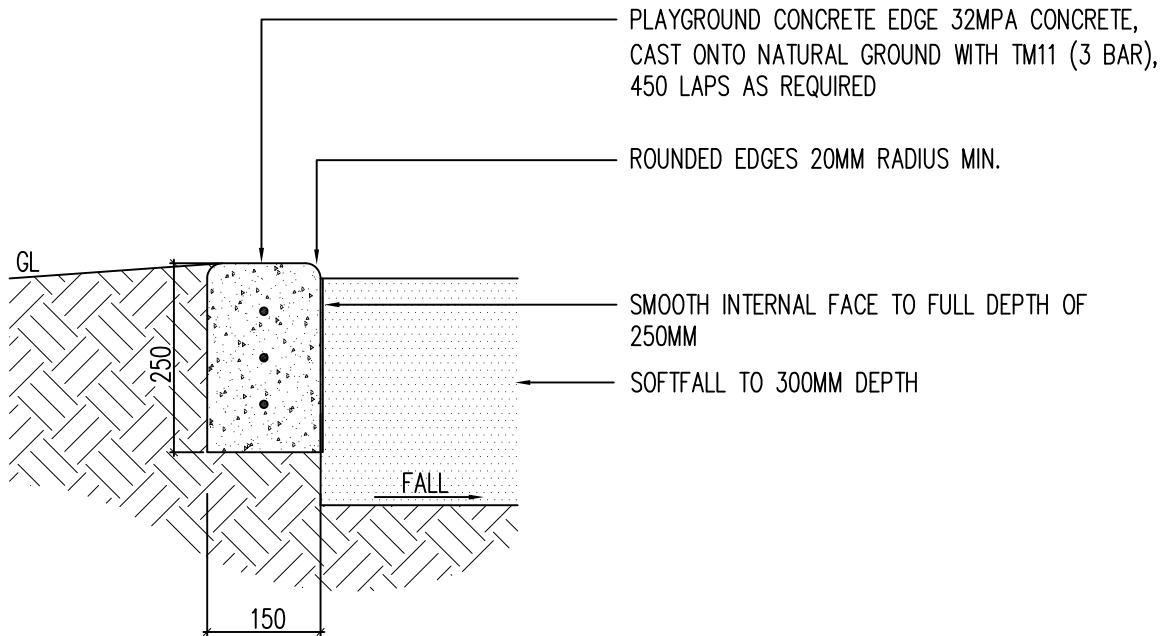

TYPICAL CROSS SECTION FOR
PLAYGROUND CONCRETE EDGE

NOTES

1. PROVIDE TOOLED JOINTS AT 1M CENTRES, 5MM MINIMUM DEPTH.

CITY OF CASEY

PLAYGROUND ELEMENTS
PLAYGROUND CONCRETE EDGE DETAIL

Robert

MANAGER OF ENGINEERING &
ENVIRONMENTAL SERVICES

LAST UPDATE 09.11.2012

AMENDMENTS:

S-1011

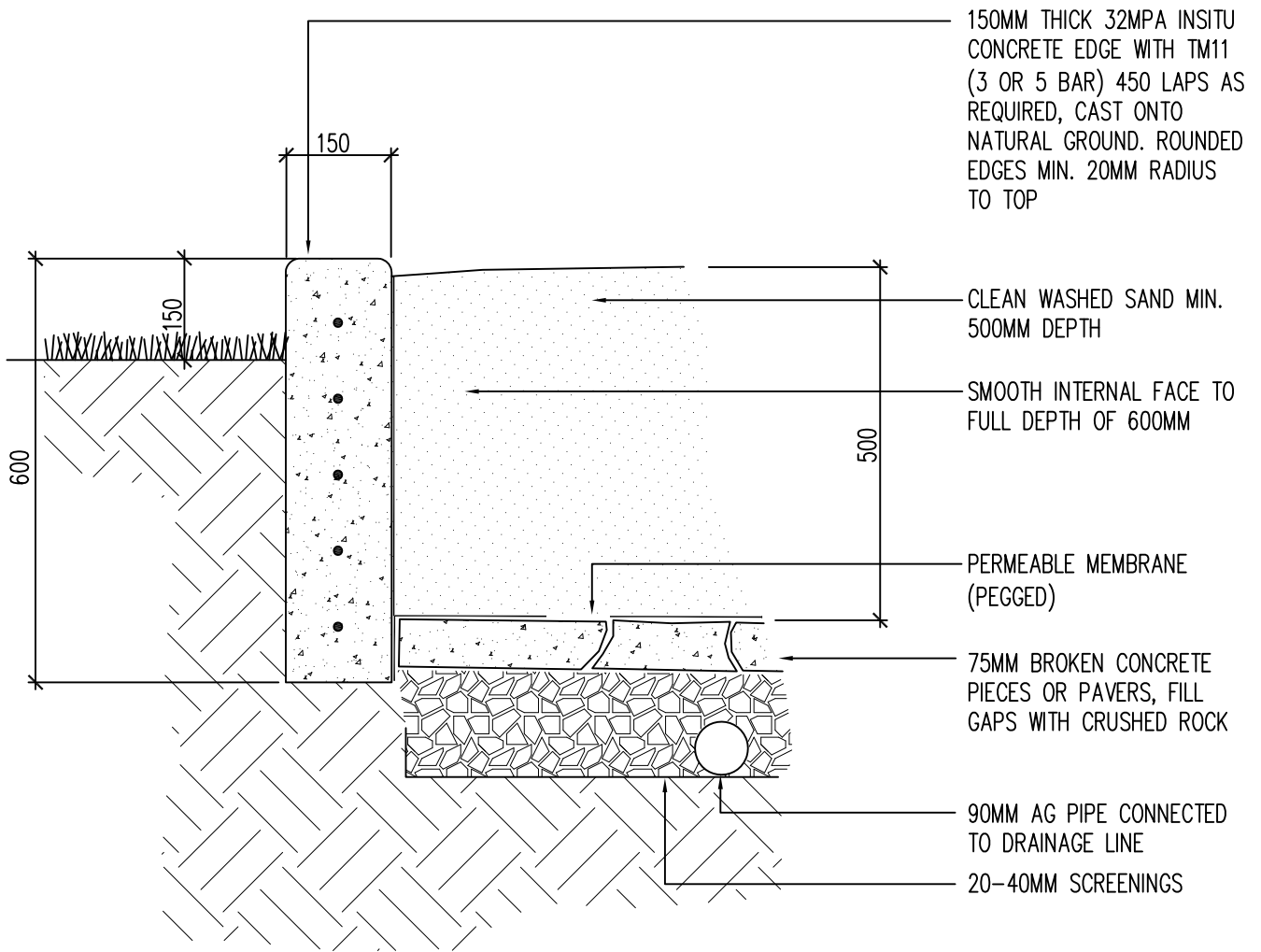

TYPICAL CROSS SECTION FOR
PLAYGROUND CONCRETE EDGE (RAISED)

NOTES

1. PROVIDE TOOLED JOINTS AT 1M CENTRES, 5MM MINIMUM DEPTH.

CITY OF CASEY

PLAYGROUND ELEMENTS
PLAYGROUND CONCRETE EDGE (RAISED) DETAIL

Robert

MANAGER OF ENGINEERING &
ENVIRONMENTAL SERVICES
LAST UPDATE 09.11.2012

AMENDMENTS:

S-1012

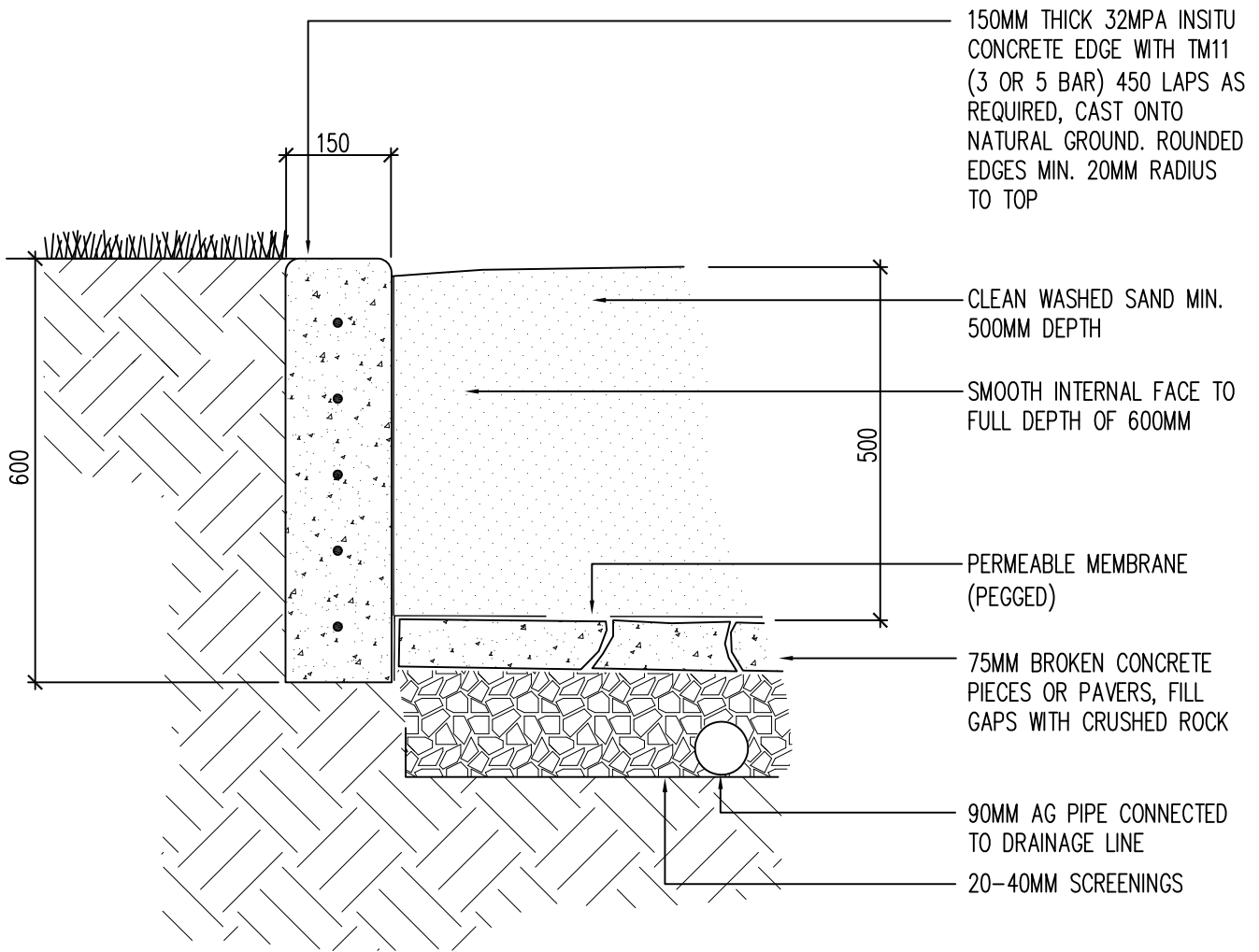

TYPICAL CROSS SECTION FOR
PLAYGROUND CONCRETE EDGE (FLUSH)

NOTES

1. PROVIDE TOOLED JOINTS AT 1M CENTRES, 5MM MINIMUM DEPTH.

CITY OF CASEY

PLAYGROUND ELEMENTS

PLAYGROUND CONCRETE EDGE (FLUSH) DETAIL

MANAGER OF ENGINEERING &
ENVIRONMENTAL SERVICES

LAST UPDATE 09.11.2012

AMENDMENTS:

S-1013

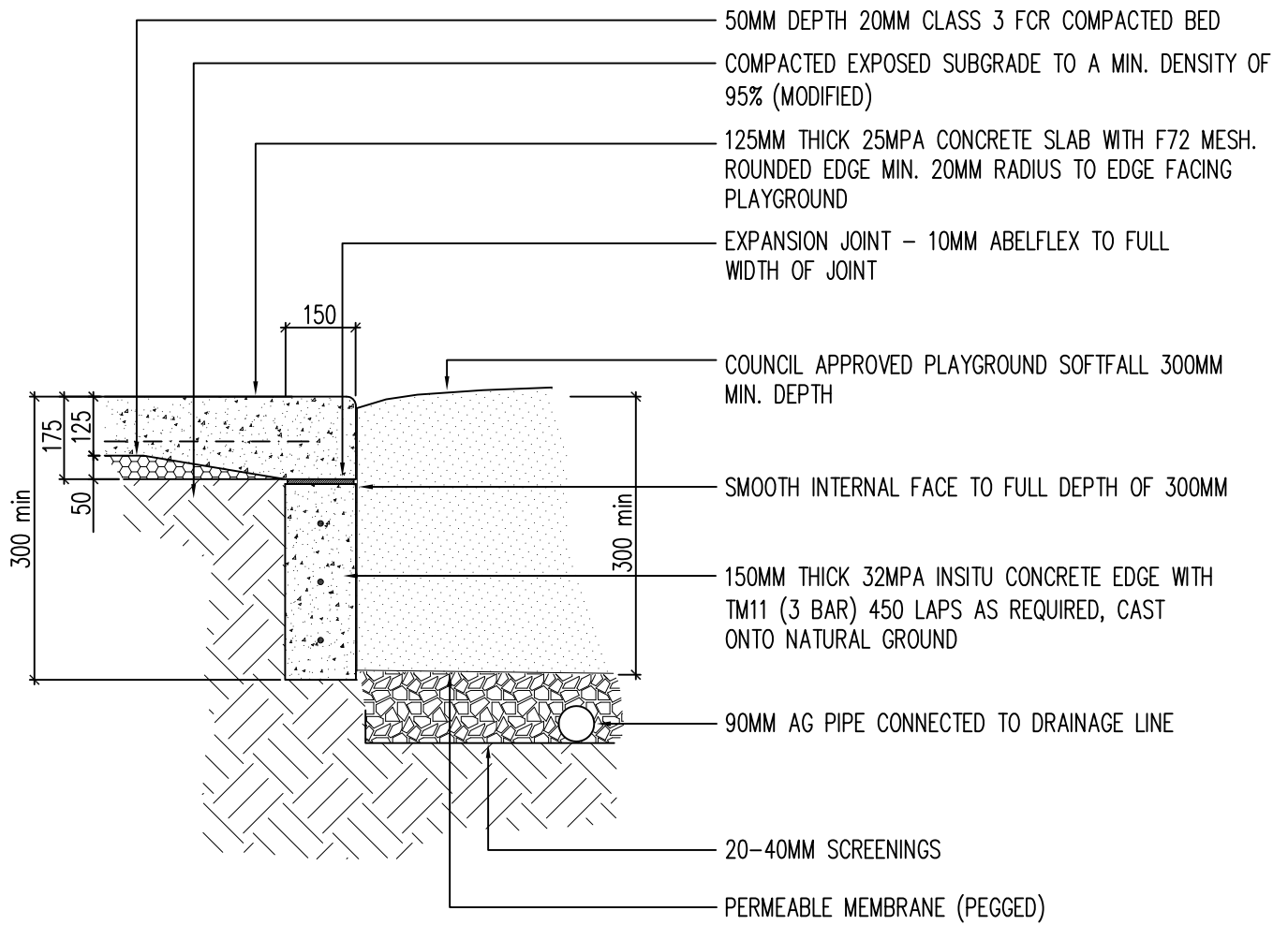

TYPICAL CROSS SECTION FOR PLAYGROUND
CONCRETE EDGE AND FOOTPATH

NOTES

1. PROVIDE VERTICAL TOOLED JOINTS AT 1M CENTRES, 5MM MINIMUM DEPTH.
2. REFER CITY OF CASEY STANDARD DRAWING S-402, FOR FOOTPATH DETAILS.

CITY OF CASEY

PLAYGROUND ELEMENTS

PLAYGROUND CONCRETE EDGE AND FOOTPATH DETAIL

MANAGER OF ENGINEERING &
ENVIRONMENTAL SERVICES

LAST UPDATE 09.11.2012

AMENDMENTS:

S-1014

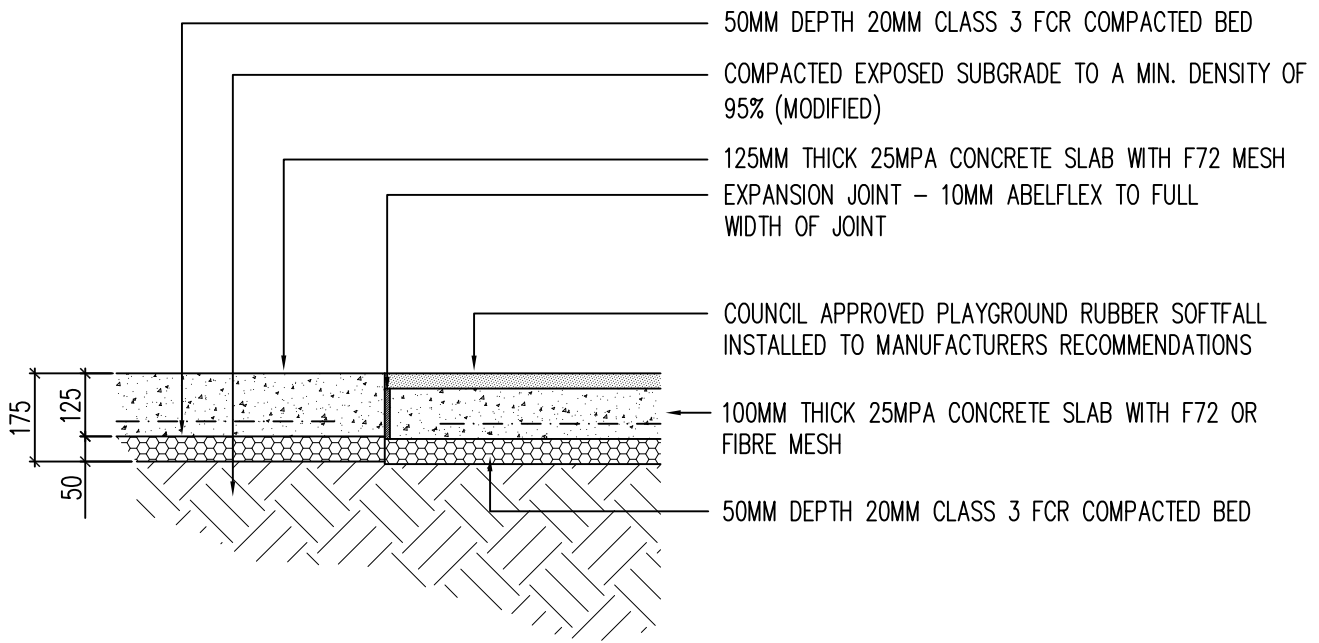

TYPICAL CROSS SECTION FOR PLAYGROUND RUBBER SOFTFALL AND CONCRETE EDGE

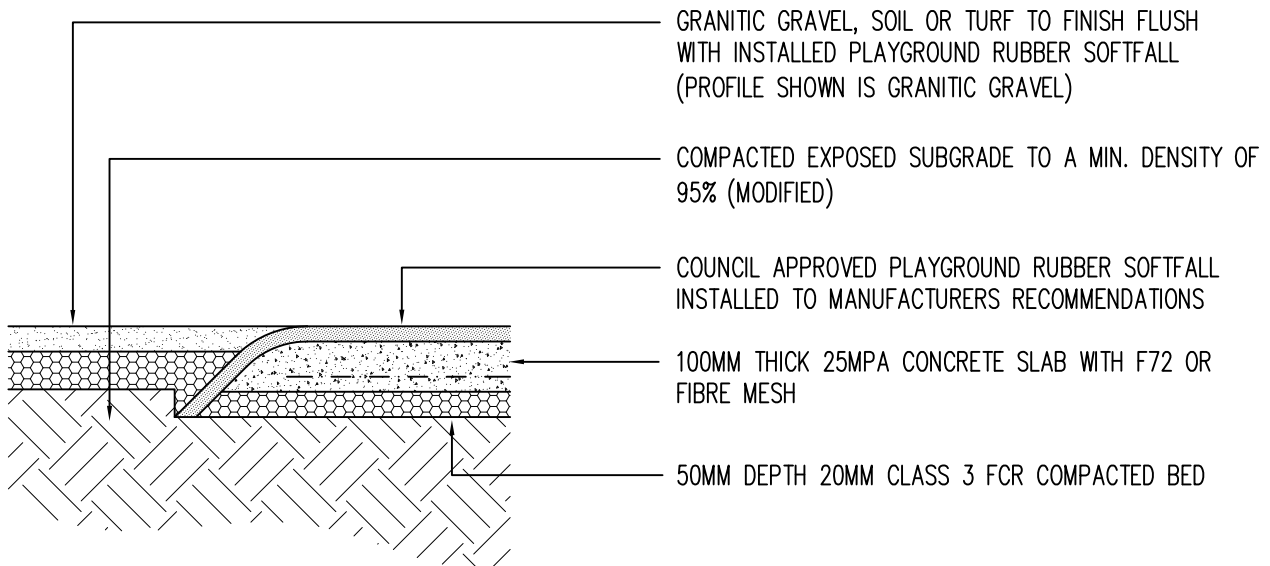

TYPICAL CROSS SECTION FOR PLAYGROUND RUBBER SOFTFALL AND TIMBER EDGE

NOTES

1. REFER CITY OF CASEY STANDARD DRAWING S-402, FOR FOOTPATH DETAILS.

CITY OF CASEY

PLAYGROUND ELEMENTS
PLAYGROUND RUBBER SOFTFALL EDGE DETAILS

MANAGER OF ENGINEERING & ENVIRONMENTAL SERVICES

LAST UPDATE 09.11.2012

AMENDMENTS:

S-1015

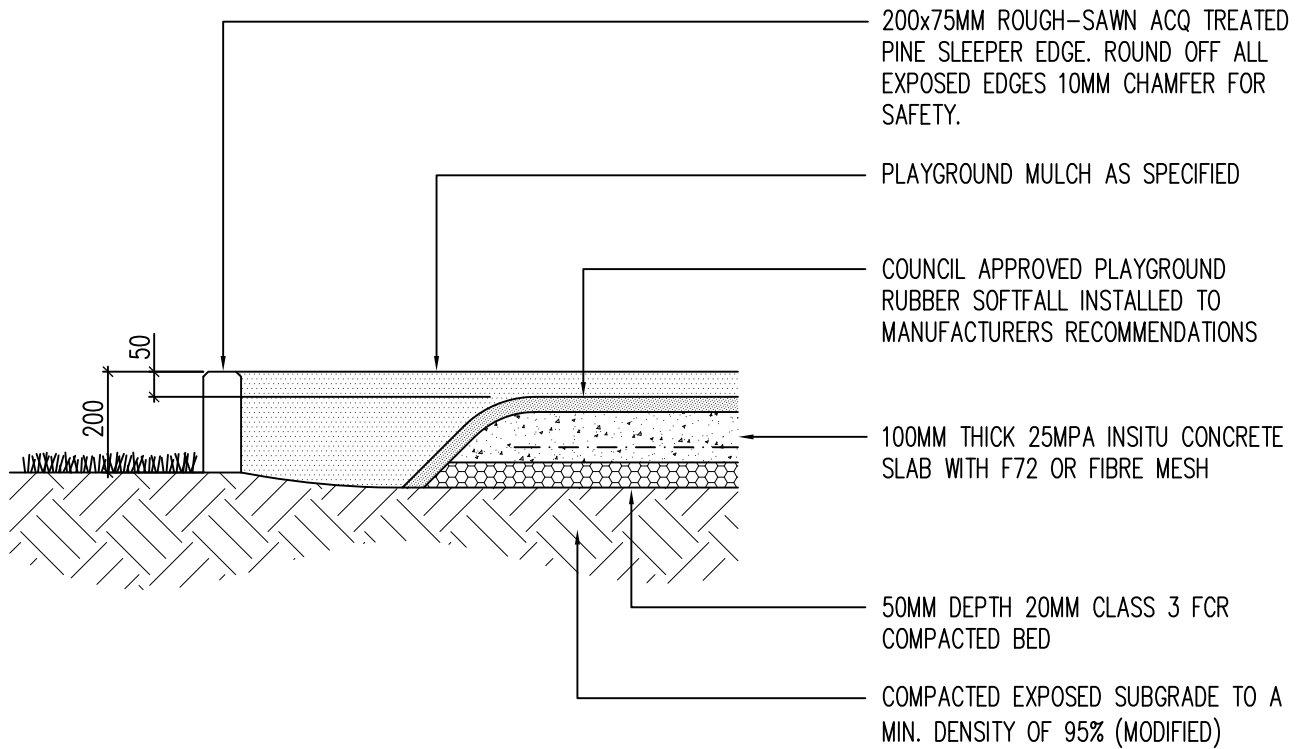

TYPICAL CROSS SECTION FOR PLAYGROUND
RUBBER SOFTFALL TOUCH DOWN PAD

CITY OF CASEY

PLAYGROUND ELEMENTS

PLAYGROUND RUBBER SOFTFALL TOUCH DOWN PAD DETAIL

AMENDMENTS:

MANAGER OF ENGINEERING &
ENVIRONMENTAL SERVICES

LAST UPDATE 09.11.2012

S-1016

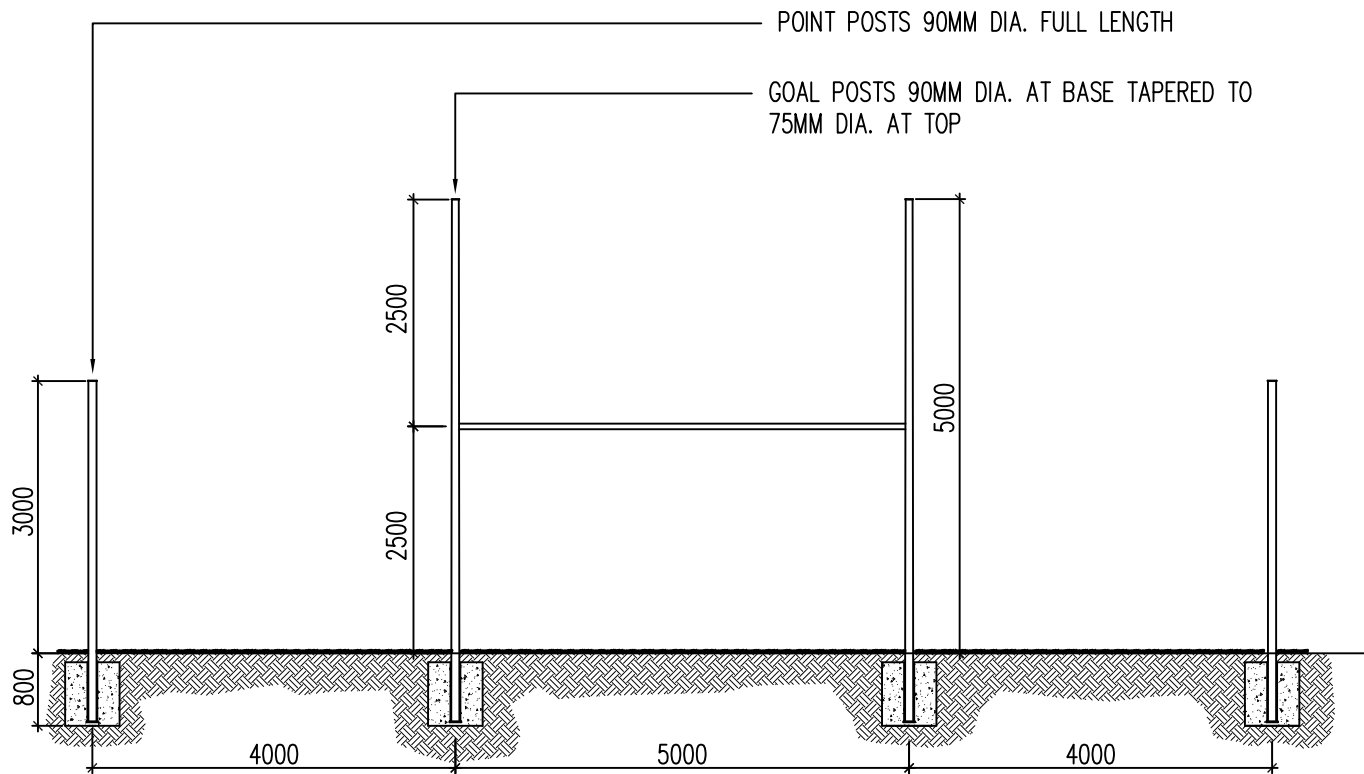

TYPICAL CROSS SECTION FOR
RECREATIONAL FUN GOAL POST

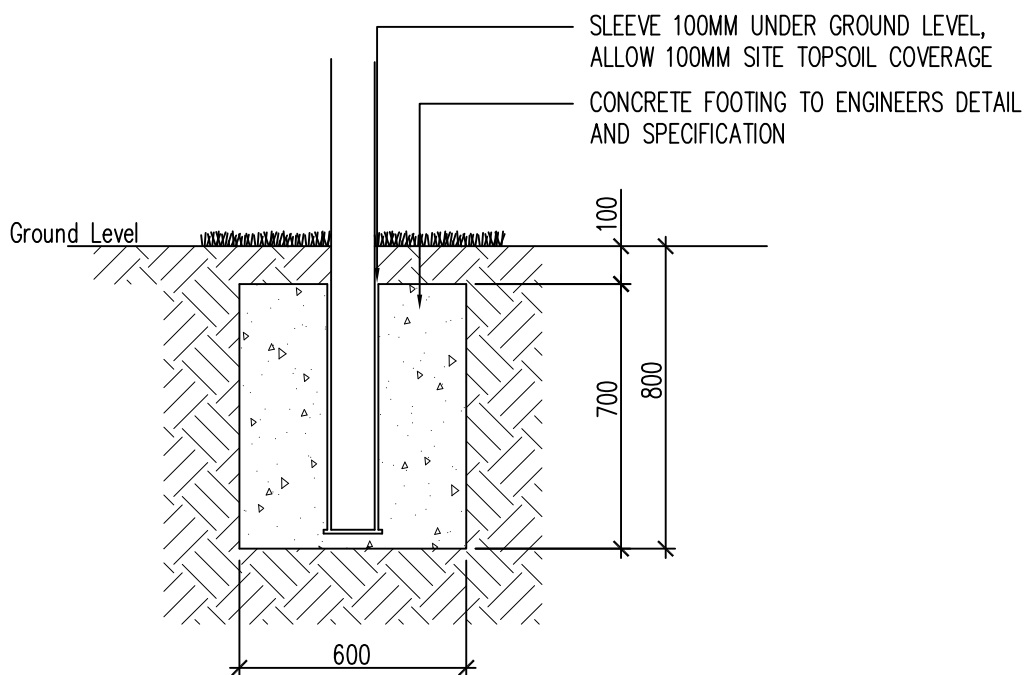

TYPICAL FOOTING DETAIL FOR
RECREATIONAL FUN GOAL POST

CITY OF CASEY

RECREATIONAL ELEMENTS
FUN GOAL POST DETAIL

MANAGER OF ENGINEERING &
ENVIRONMENTAL SERVICES
LAST UPDATE 09.11.2012

AMENDMENTS:

S-1017

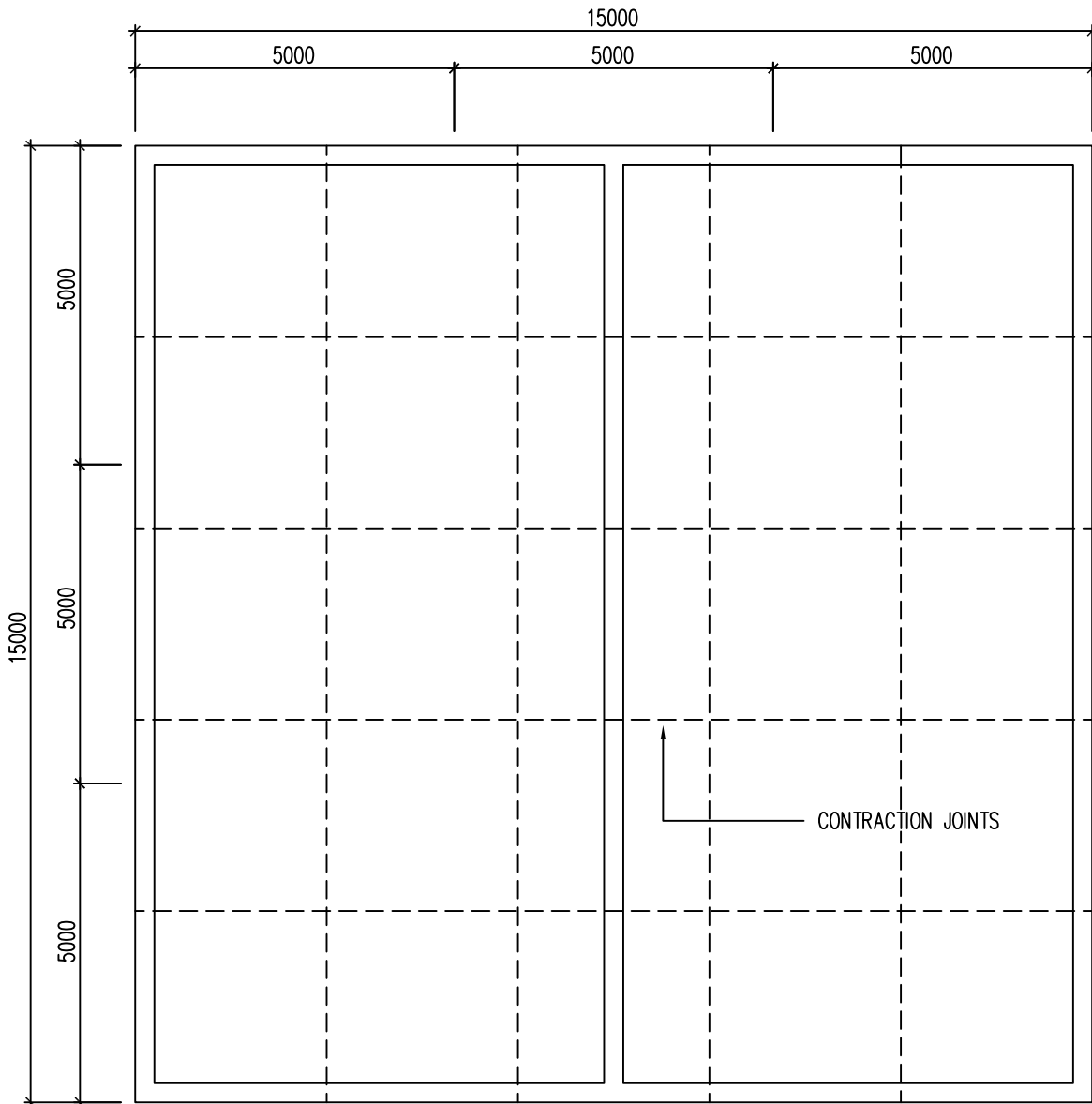

TYPICAL PLAN OF CONCRETE SLAB SHOWING CONTRACTION JOINTS

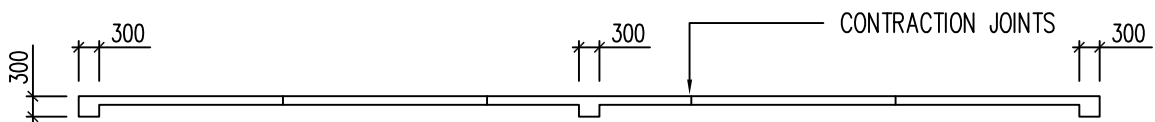

TYPICAL CROSS SECTION OF CONCRETE SLAB

NOTES

1. SIZE OF SMALL HARD COURT MAY VARY AS SPECIFIED
EG 13Mx13M, 13Mx14M, 13Mx15M, 14Mx14M,
14Mx15M, 15Mx15M.
2. PLACE TOWER OUTSIDE SLAB AT BEST LOCATION.
3. REFER TO STANDARD BASKETBALL RING AND TOWER
DETAIL DRAWING S-1020
4. TO BE READ IN CONJUNCTION WITH STANDARD
HARD COURT LAYOUT DETAIL DRAWING S-1019.
5. SURFACE GRADIENT 1 IN 100, CONSTANT ONE WAY FALL
ALONG NORTH-SOUTH ORIENTATION IN EITHER DIRECTION
TO SUIT NATURAL SURFACE.

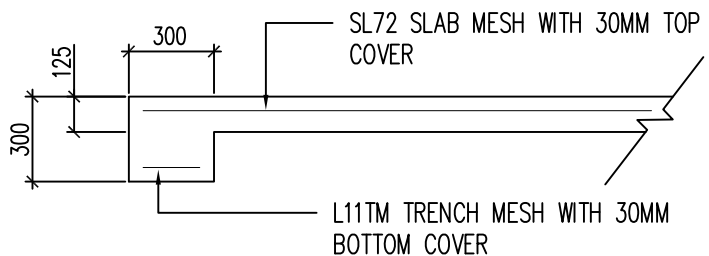

TYPICAL CROSS SECTION OF CONCRETE
SLAB SHOWING REINFORCEMENT

CITY OF CASEY

RECREATIONAL ELEMENTS
HARDCOURT SLAB DETAIL

MANAGER OF ENGINEERING &
ENVIRONMENTAL SERVICES

LAST UPDATE 09.11.2012

AMENDMENTS:

S-1018

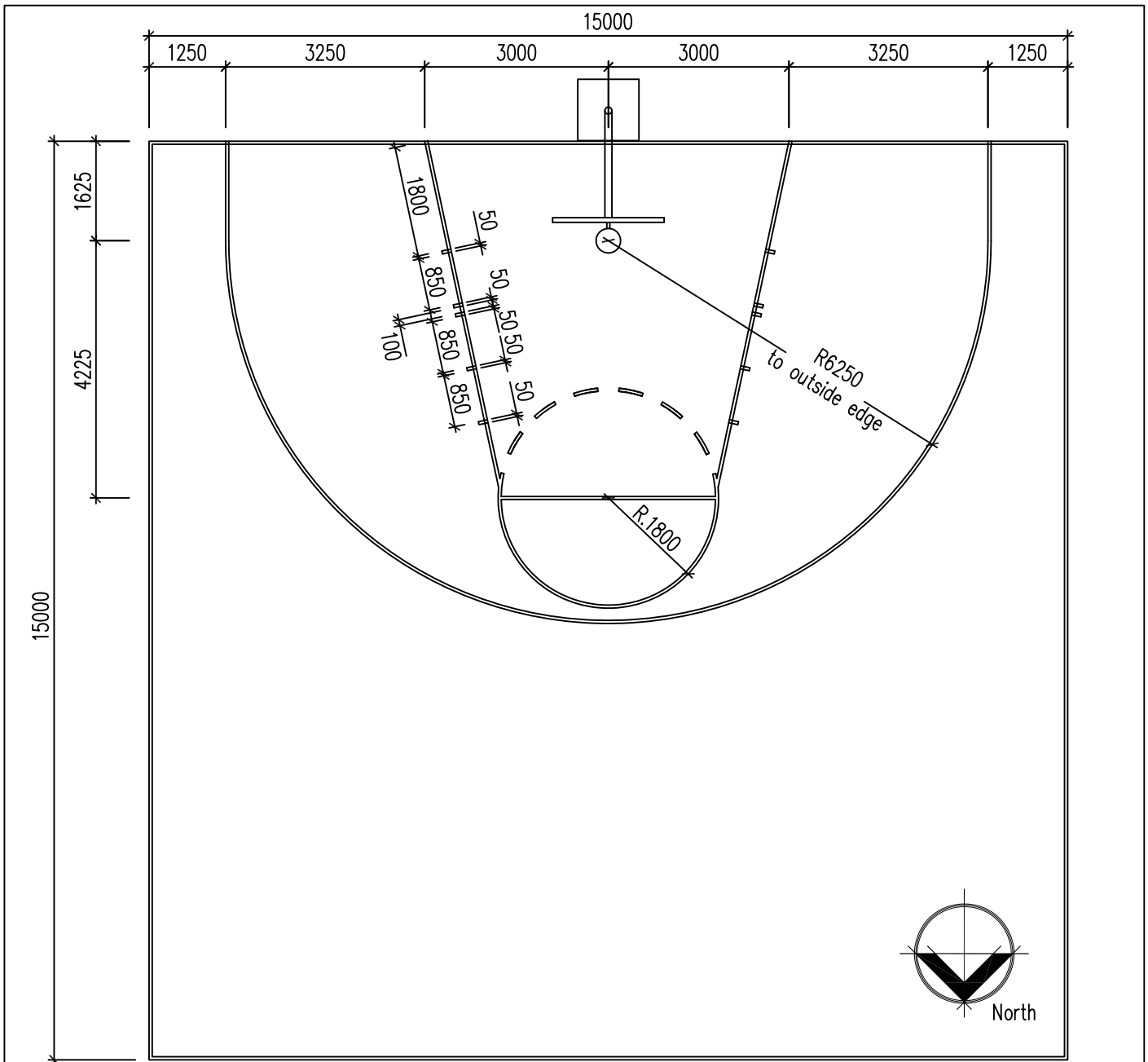

TYPICAL PLAN FOR RECREATIONAL HARD COURT LAYOUT

NOTES

1. BACKBOARD RING AND TOWER CONFIGURATION INSTALLED TO MANUFACTURERS INSTRUCTIONS, REFER TO BASKETBALL RING AND TOWER DETAIL S-1020.
2. ALL LINE MARKING TO BE 50MM WIDE.
3. FINISHED SURFACE LEVEL TO BE 50MM ABOVE EXISTING GROUND LEVEL.
4. TOP OF BASKETBALL RING TO BE 3050MM ABOVE PLAYING SURFACE.
5. ALL NUTS AND BOLTS TO BE GALVANISED ISO METRIC THREAD.
6. PAINTED COURT CONFIGURATION COULD VARY WITH SCALE OF PLAY REQUIRED AND SIZE PROVIDED.
7. ENSURE ORIENTATION OF DIRECTION OF PLAY IS ALONG A NORTH-SOUTH AXIS, PLACE BASKETBALL TOWER AT SOUTHERN END.
8. REFER TO 'TRULINE' CATALOGUE, OR SIMILAR, FOR MORE INFORMATION AND DIMENSIONS. DIMENSIONS WILL VARY WITH SIZE OF HARD COURT.

CITY OF CASEY

RECREATIONAL ELEMENTS
HARD COURT LAYOUT DETAIL

MANAGER OF ENGINEERING &
ENVIRONMENTAL SERVICES

LAST UPDATE 09.11.2012

S-1019

AMENDMENTS:

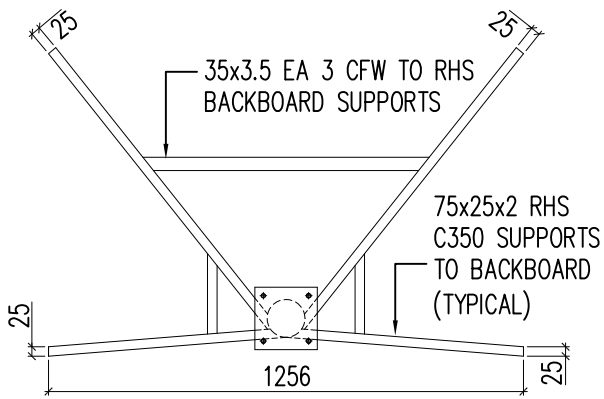

BACKBOARD SUPPORT DETAIL

165x165x6 MS BASE PLATE. 6 CFW TO CHS SPIGOT AND RHS OUTRIGGERS

PLATE DETAIL

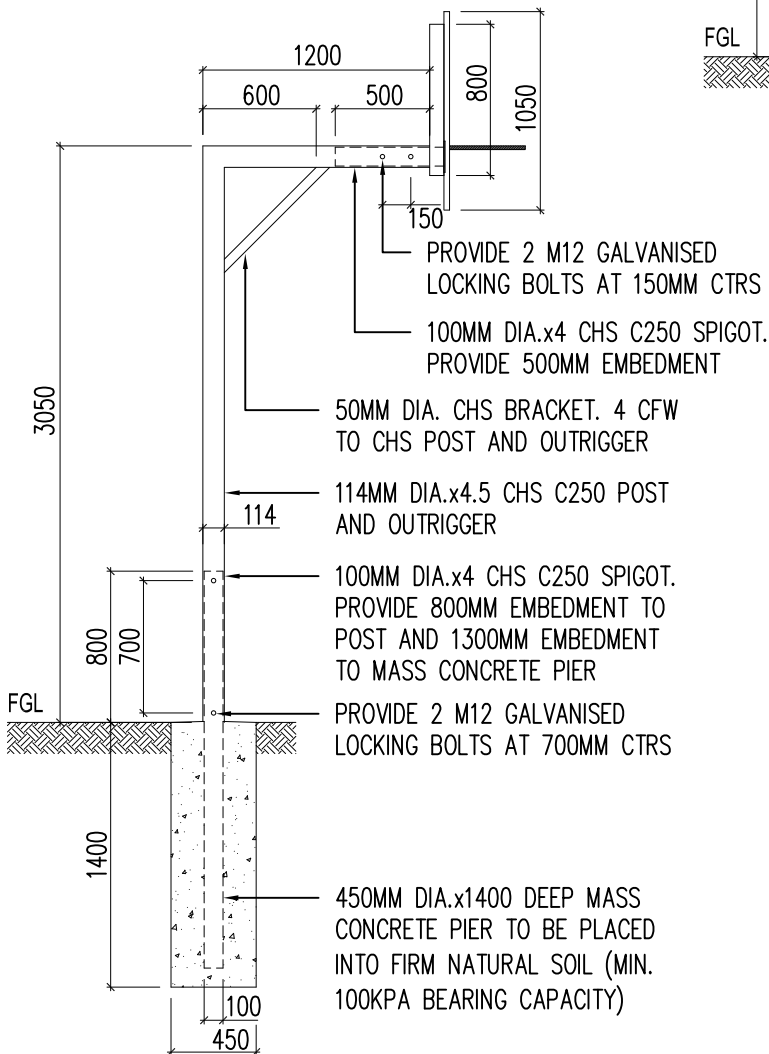
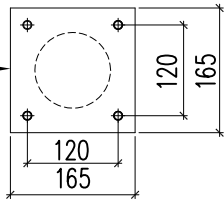

SIDE ELEVATION

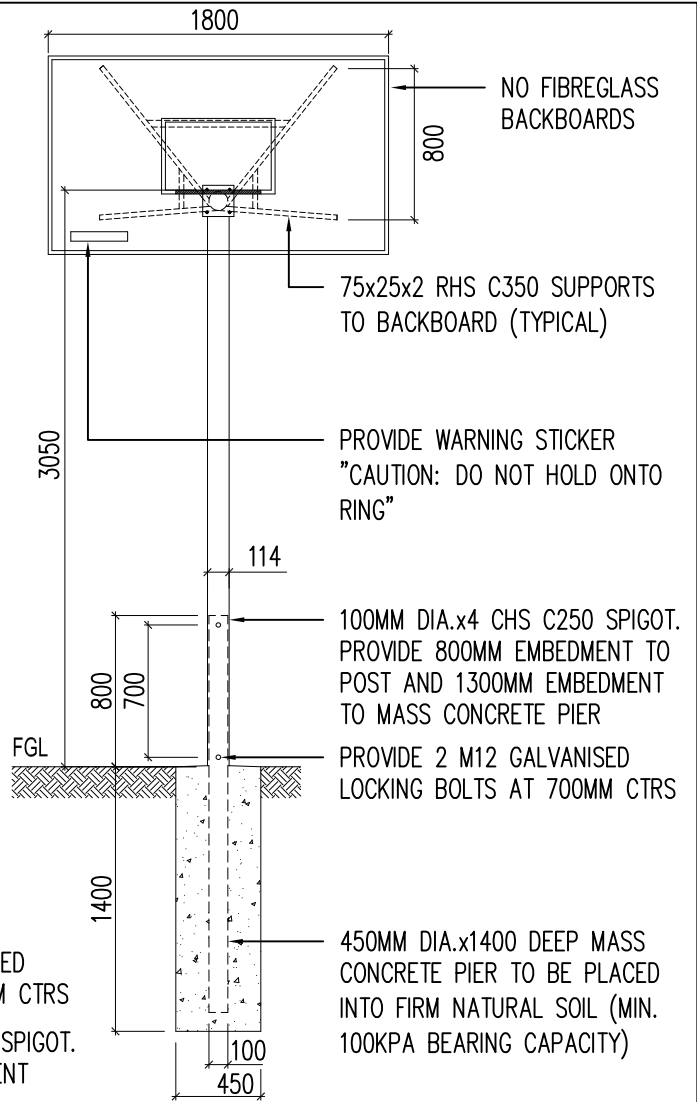

FRONT ELEVATION

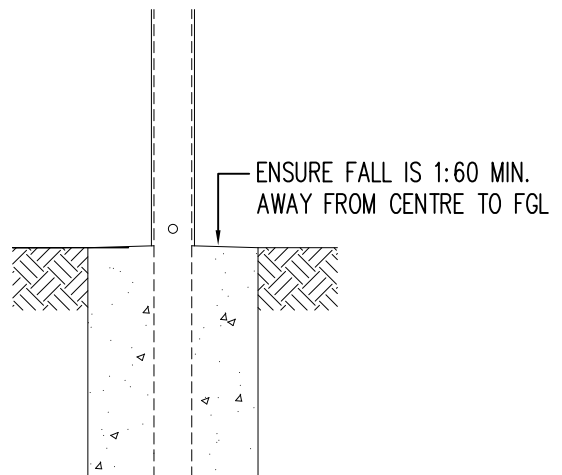

FOOTING ENLARGEMENT

CITY OF CASEY

RECREATIONAL ELEMENTS
BASKETBALL RING AND TOWER DETAIL

Shah

MANAGER OF ENGINEERING &
ENVIRONMENTAL SERVICES

LAST UPDATE 09.11.2012

AMENDMENTS:

S-1020

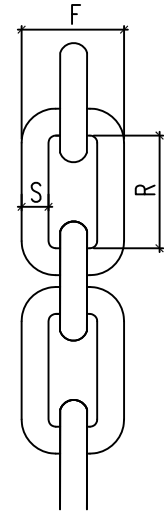
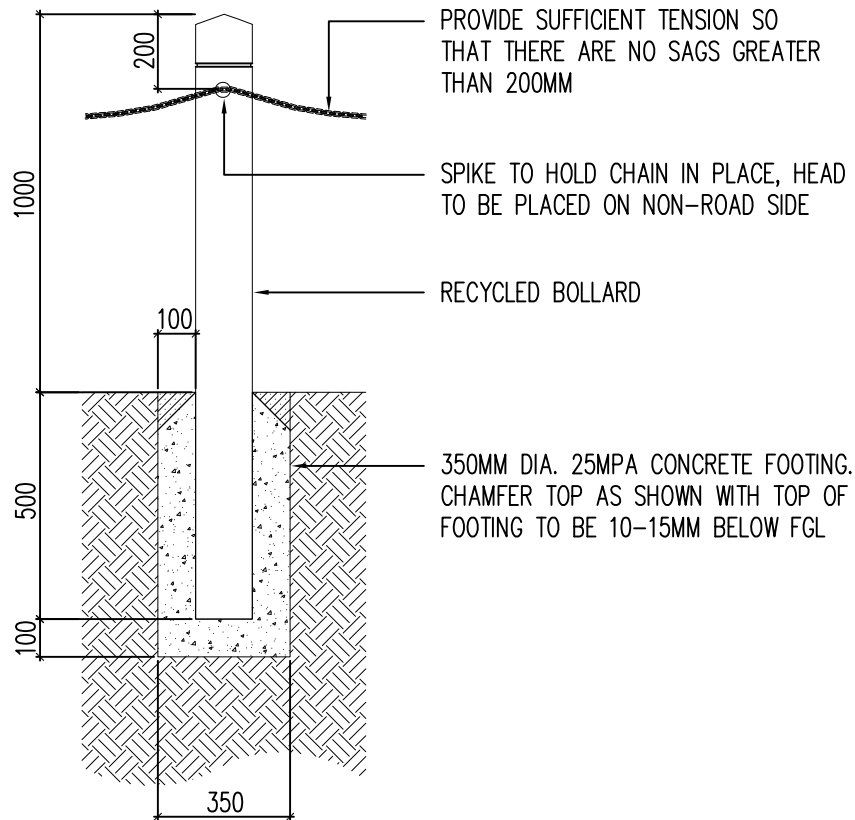

TYPICAL CHAIN

TYPICAL CROSS SECTION FOR RECYCLED BOLLARD WITH CHAIN

NOTES

1. CHAIN TO BE REGULAR LINK GALVANISED STEEL.
2. CHAIN SIZE TO BE 10MM
F 36MM
R 41.5MM
S 10MM
3. SPIKE PLACED IN EACH POST TO SECURE CHAIN FROM MOVING.

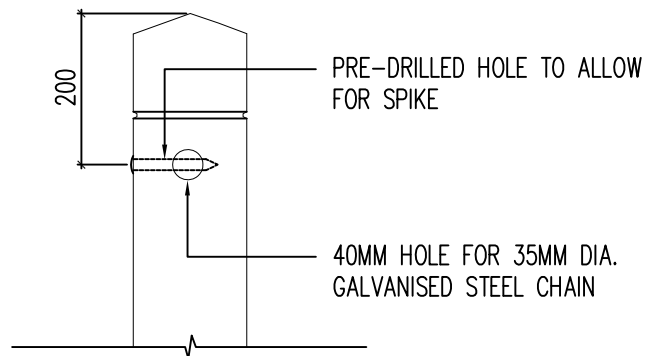

TYPICAL CHAIN CONNECTION

CITY OF CASEY

FURNITURE

RECYCLED BOLLARD WITH CHAIN DETAIL

MANAGER OF ENGINEERING & ENVIRONMENTAL SERVICES

LAST UPDATE 09.11.2012

AMENDMENTS:

S-1021

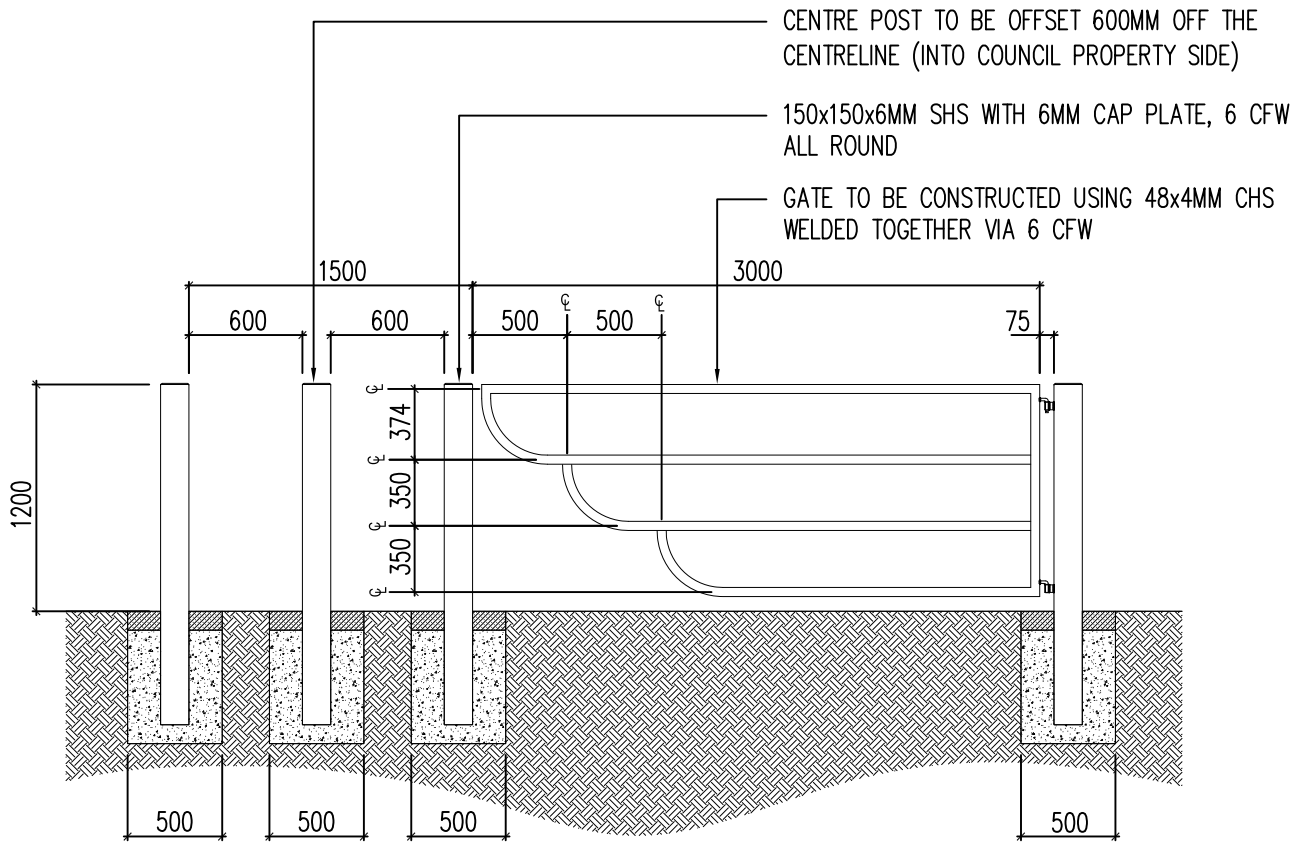

TYPICAL CROSS SECTION FOR GATE

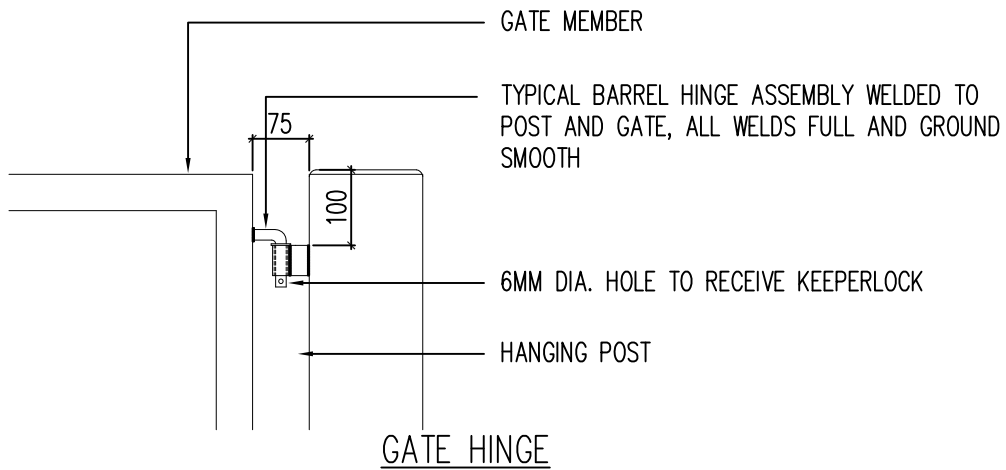

CITY OF CASEY

FURNITURE
GATE DETAIL

MANAGER OF ENGINEERING & ENVIRONMENTAL SERVICES
LAST UPDATE 09.11.2012

AMENDMENTS:

S-1022

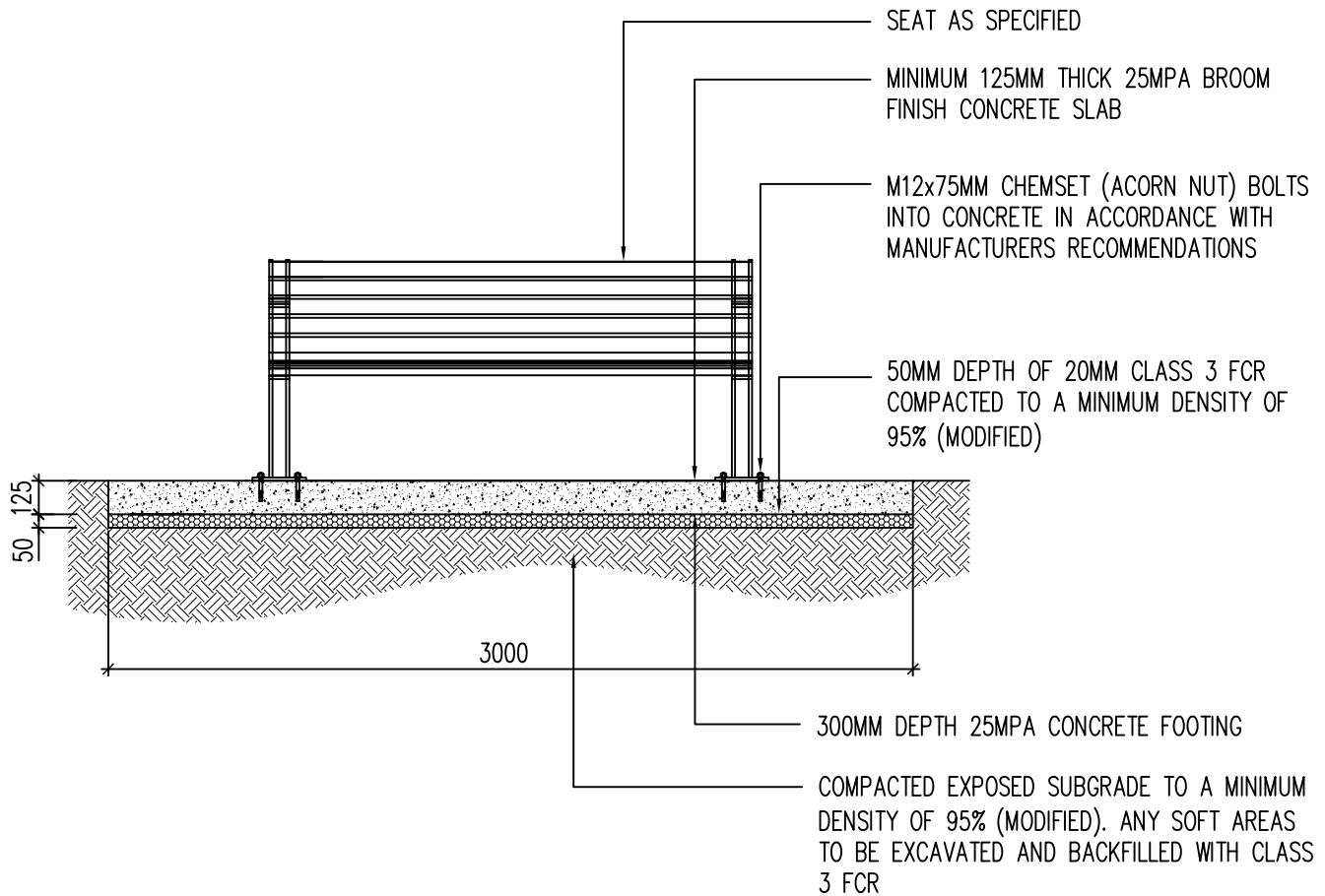

TYPICAL CROSS SECTION
FOR SEAT

CITY OF CASEY

FURNITURE
SEAT DETAIL

MANAGER OF ENGINEERING &
ENVIRONMENTAL SERVICES
LAST UPDATE 09.11.2012

AMENDMENTS:

S-1023

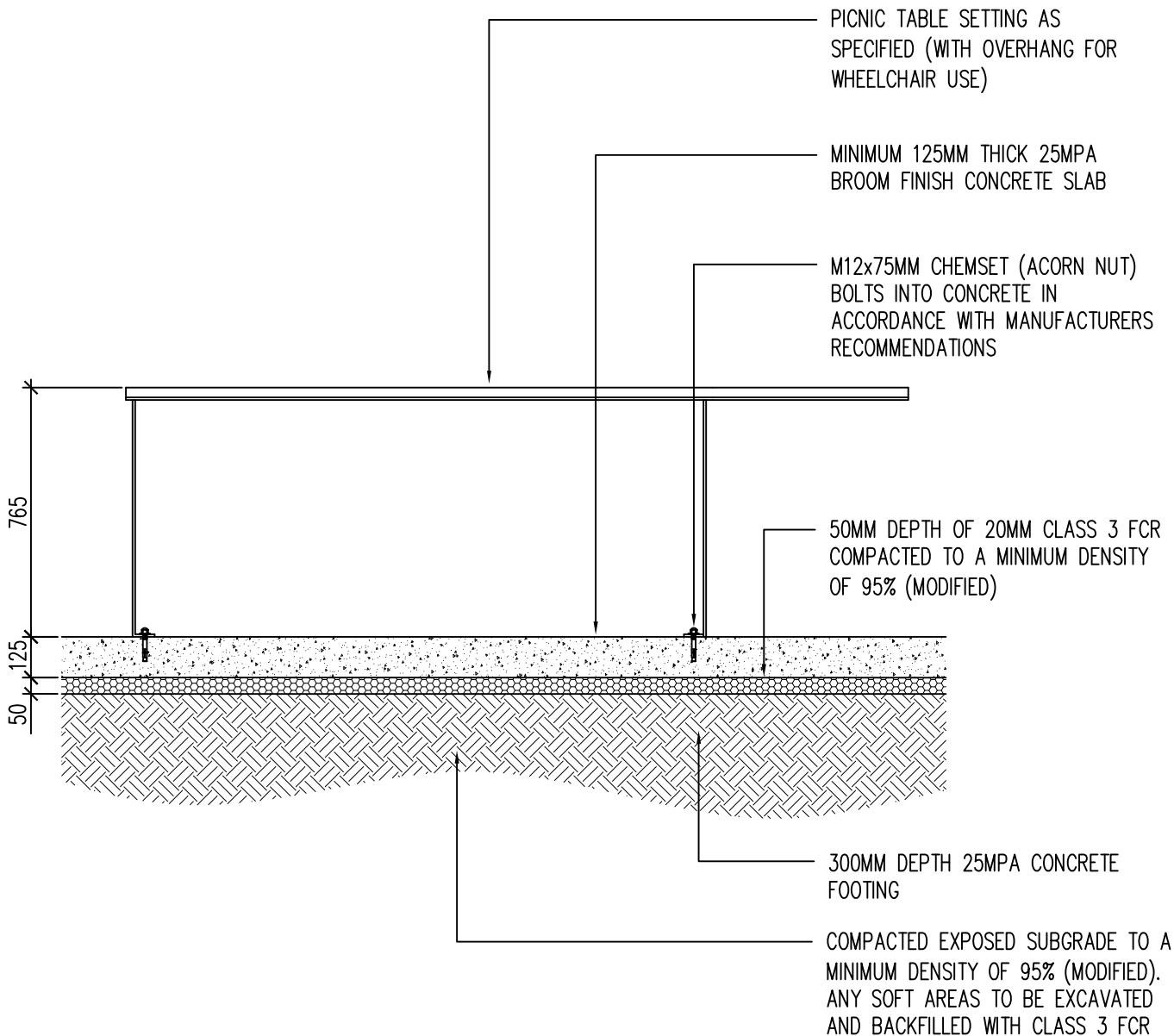

TYPICAL CROSS SECTION
FOR PICNIC TABLE SETTING

CITY OF CASEY

FURNITURE
PICNIC TABLE SETTING DETAIL

MANAGER OF ENGINEERING &
ENVIRONMENTAL SERVICES
LAST UPDATE 09.11.2012

S-1024

AMENDMENTS:

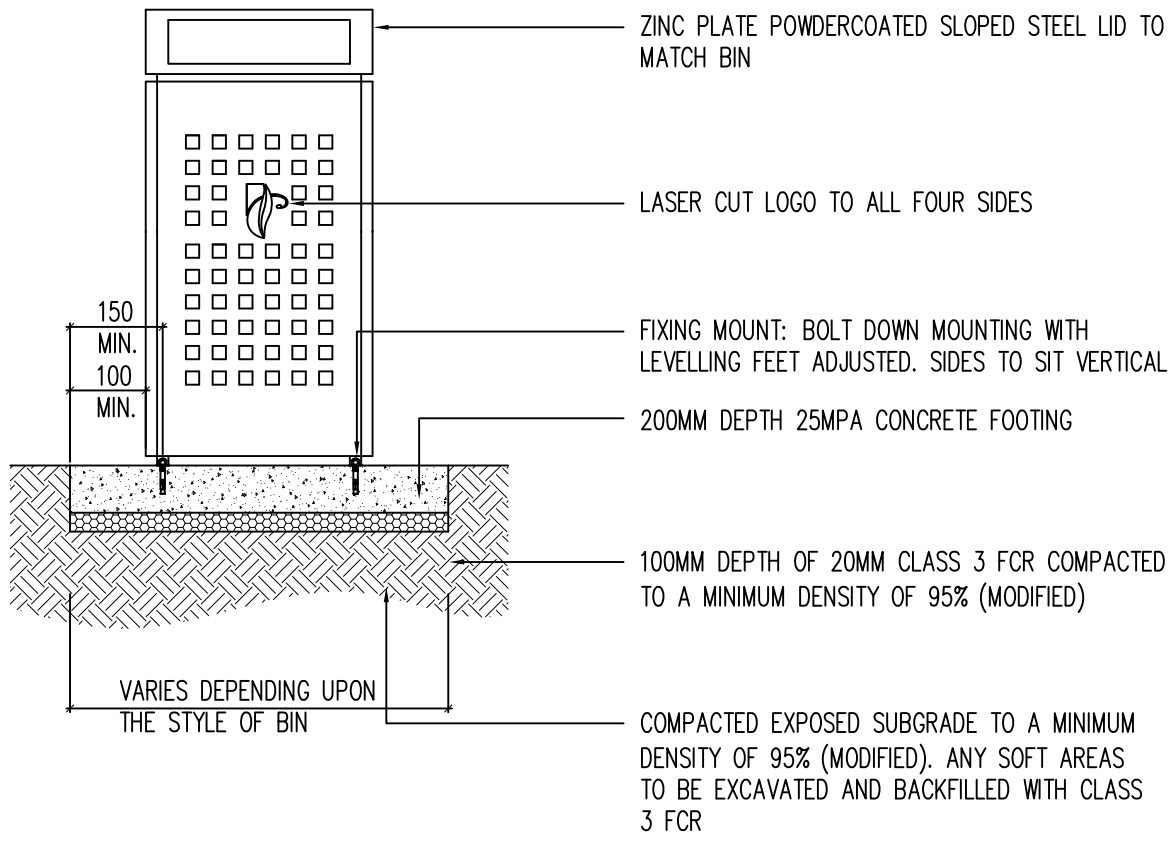

TYPICAL CROSS SECTION FOR BIN SURROUND

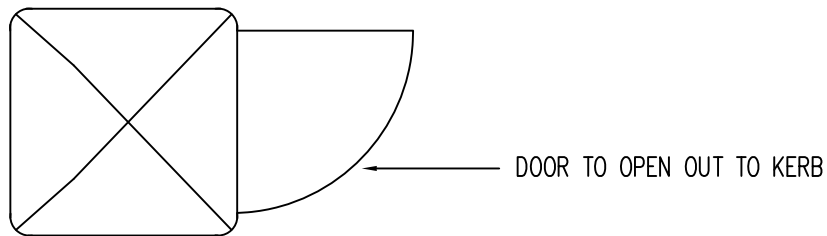

TYPICAL PLAN FOR BIN SURROUND

NOTES

1. LITTER BIN SURROUND TO BE POWDERCOATED 'CASEY' GREEN TO SIDES AND DOOR, UNLESS SPECIFIED OTHERWISE.
2. TRIANGULAR KEY OPERATED LOCK.
3. 120 LITRE WHEELIE BIN SIZE WITH 1315x600x600MM SURROUND.

CITY OF CASEY

FURNITURE
BIN SURROUND DETAIL

MANAGER OF ENGINEERING & ENVIRONMENTAL SERVICES
LAST UPDATE 09.11.2012

AMENDMENTS:

S-1025